



CITY OF HAM LAKE

15544 Central Avenue NE
Ham Lake, Minnesota 55304
(763) 434-9555
Fax (763) 434-9599

CITY OF HAM LAKE PLANNING COMMISSION AGENDA MONDAY, DECEMBER 11, 2023

CALL TO ORDER: 6:00 p.m.

PLEDGE OF ALLEGIANCE

APPROVAL OF MINUTES: November 13, 2023

PUBLIC HEARINGS:

6:01 p.m. Nicholas Holm of Twin Town Demolition requesting a Conditional Use Permit to operate a demolition for renovation construction service contractor business at 16648 Polk Street NE

NEW BUSINESS:

1. Nicholas Holm of Twin Town Demolition requesting Commercial Site Plan approval to construct a 4,608 square foot office/warehouse building at 16648 Polk Street NE. PID# 08-32-23-33-0013

COMMISSION BUSINESS:

1. City Council Update

CITY OF HAM LAKE
PLANNING COMMISSION MINUTES
MONDAY, NOVEMBER 13, 2023

The Ham Lake Planning Commission met for its regular meeting on Monday, November 13, 2023 in the Council Chambers at Ham Lake City Hall located at 15544 Central Avenue NE in Ham Lake, Minnesota.

MEMBERS PRESENT: Commissioners Brian Pogalz, Kyle Lejonvarn, Jeff Entsminger, Erin Dixson and David Ross

MEMBERS ABSENT: Commissioners Dave Ringler and Jonathan Fisher

OTHERS PRESENT: City Engineer Dave Krugler and Building and Zoning Clerk Jennifer Bohr

CALL TO ORDER: Chair Pogalz called the meeting to order at 6:00 p.m.

PLEDGE OF ALLEGIANCE:

The pledge of allegiance was recited by all in attendance.

APPROVAL OF MINUTES:

Motion by Ross, seconded by Dixson, to approve the minutes of the October 23, 2023 Planning Commission meeting as written. All present in favor, motion carried.

PUBLIC HEARING: None

OLD BUSINESS:

Jeff Stalberger, MN Development LLC, requesting Sketch Plan approval for a development located at 2506 Swedish Drive NE (47 Residential Single Family lots and 1 outlot) in Section 4

Mr. Jeff Stalberger, Sr. Mr. Jeff Stalberger, Jr. and Mr. Ryan Stalberger were present. Chair Pogalz stated this matter was tabled at the previous meeting due to the need to determine the amount of Municipal State Aid (MSA) mileage available, resolve right-of-way (ROW) concerns and obtain direction from the Park Committee on parkland dedication requirements. Chair Pogalz asked the applicant for comment. Mr. Stalberger Sr. spoke on behalf of the project. Mr. Stalberger stated he spoke with the City's Engineers to determine how the plat could be modified so that all right-of-way dedication would be within the plat's boundaries. Mr. Stalberger stated another small outlot was created adjacent to parcel 04-32-23-13-0005 south of Swedish Drive NE to modify the limits of the plat. Mr. Stalberger stated Outlot B is approximately 0.79 acres. Mr. Stalberger stated he is willing to donate that outlot to the church. Engineer Krugler

agreed the road must be constructed within dedicated ROW within the plat border limits. Engineer Krugler stated the issue with the original sketch plan submitted was that the western plat border did not dedicate ROW on the north side of Swedish Drive NE which would have required the developer to obtain ROW from other property owners. Chair Pogalz asked Engineer Krugler about available MSA miles. Engineer Krugler stated the City currently has 480-feet of mileage available to dedicate to an MSA roadway. Engineer Krugler stated the connect between Xylite Street NE and the intersection of 181st Avenue NE and Baltimore Street NE plat is approximately 1.7 miles or 9,000-feet in length. Engineer Krugler stated Mr. Stalberger's current sketch plan dedicates sufficient ROW to accommodate 30 mile per hour curves so additional ROW will not need to be acquired if or when Swedish Drive NE can be designated as an MSA road. Engineer Krugler stated Mr. Stalberger will not need to construct Swedish Drive NE to MSA standards. Chair Pogalz stated a memo from Administrator Webster, on behalf of the Park Committee, recommends acquiring a 20-foot wide trail easement along the west side of Xylite Street NE with the balance of the parkland dedication requirement being monies in lieu of parkland. Mr. Stalberger stated that was acceptable. **Motion by Lejonvarn, seconded by Dixon, to recommend approval of the Sketch Plan for a development located at 2506 Swedish Drive NE as presented by Jeff Stalberger of MN Development, LLC for 47 Single Family Residential lots and one outlot in Section 4, subject to a minimum design speed of 30 miles per hour on Swedish Drive NE, combining Outlot B with adjacent parcel 04-32-23-13-0005 after final plat approval, parkland dedication consisting of the dedication of a 20-foot wide trail easement along the west side of Xylite Street NE (County Road 68) for a future bike path and the remainder in monies in lieu of parkland.**

There was discussion about the revised sketch plan now including 47 residential single family lots and two outlots. The motion was revised.

Motion by Lejonvarn, seconded by Dixon, to recommend approval of the Sketch Plan for a development located at 2506 Swedish Drive NE as presented by Jeff Stalberger of MN Development, LLC for 47 Single Family Residential lots and two outlots in Section 4, subject to a minimum design speed of 30 miles per hour on Swedish Drive NE, combining Outlot B with adjacent parcel 04-32-23-13-0005 after final plat approval, parkland dedication consisting of the dedication of a 20-foot wide trail easement along the west side of Xylite Street NE (County Road 68) for a future bike path and the remainder in monies in lieu of parkland, meeting all the requirements of the City Engineer and meeting all City, State and County requirements. All present in favor, motion carried. *This application will be placed on the City Council's Monday, November 20, 2023 agenda.*

NEW BUSINESS: None

COMMISSION BUSINESS:

City Council Update

Chair Pogalz stated the City Council concurred with the Commission's recommendations to approve the Conditional Use Permit and commercial site plan for Ryan Becker of

Unlimited Concrete Concepts, LLC. A planning commissioner will not be present at the November 20, 2023 City Council meeting.

ADJOURNMENT:

Motion by Dixon, seconded by Lejonvarn, to adjourn the Planning Commission meeting at 6:12 p.m. All present in favor, motion carried.

Jennifer Bohr
Building and Zoning Clerk

**CITY OF HAM LAKE
PLANNING COMMISSION REQUEST APPLICATION
INSPECTION REPORT**

MTG DATE: December 11, 2023

INSPECTION ISSUED TO: Erin Dixon

APPLICANT/CONTACT: Nick Holm, Owner

TELEPHONE NUMBER: 612-267-046/nick@twintowndemolition.com

BUSINESS/PLAT NAME: Twin Town Demolition

ADDRESS/LOCATION OF INSPECTION: 16648 Polk St NE (Creekside Farms Dev)

APPLICATION FOR: Conditional Use Permit/Commercial Site Plan

RECOMMENDATION: _____

DATE: _____

PLANNING COMMISSIONER SIGNATURE: _____



CITY OF HAM LAKE

PLANNING REQUEST

15544 Central Avenue NE

Ham Lake, MN 55304

Phone (763) 434-9555 Fax (763) 235-1697

Date of Application 11/21/2023

Date of Receipt 11-21-23
Receipt # 98250

Meeting Appearance Dates:
Planning Commission 12-11-23 City Council _____

Please check request(s):

- Metes & Bounds Conveyance
- Sketch Plan
- Preliminary Plat Approval*
- Final Plat Approval
- Rezoning*
- Multiple Dog License*
- Commercial Building Site
- Certificate of Occupancy
- Home Occupation Permit
- Conditional Use Permit (New)*
- Conditional Use Permit (Renewal)
- Other

***NOTE: Advisory Signage is required for land use alterations and future road connections. This application also requires a Public Hearing. Such fees shall be deducted from deposit.**

Development/Business Name: Twin Town Demolition

Address/Location of property: 16648 Polk Street NE HAM LAKE

Legal Description of property: Lot 5, Block 3, Greeside Farms

PIN # 08-32-23-33-0013 Current Zoning CD-2 Proposed Zoning CD-2

Notes: _____

Applicant's Name: Nicholas Holm

Business Name: Twin Town Demolition

Address 13385 707 TH AVE NW

City Elk River State MN Zip Code 55330

Phone _____ Cell Phone 612-267-0461 Fax _____

Email address nick@twin town Demolition .com

You are advised that the 60-day review period required by Minnesota Statutes Chapter 15.99 does not begin to run until all of the required items have been received by the City of Ham Lake.

SIGNATURE Nicholas Holm DATE 11/21/2023

- FOR STAFF USE ONLY -

ACTION BY: Planning Commission _____
City Council _____

PROPERTY TAXES CURRENT **YES** NO

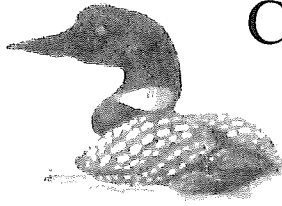

CITY OF HAM LAKE

15544 Central Avenue NE
Ham Lake, Minnesota 55304
(763) 434-9555
info@ci.ham-lake.mn.us

NOTICE OF PUBLIC HEARING
CITY OF HAM LAKE
COUNTY OF ANOKA
STATE OF MINNESOTA

TAKE NOTICE, that pursuant to the requirements of Minnesota Law, a Public Hearing shall be held before the Ham Lake Planning Commission on Monday, December 11, 2023 at 6:01 p.m. at the Ham Lake City Hall located at 15544 Central Avenue NE for the purpose of considering the application of Nicholas Holm, requesting a Conditional Use Permit to operate Twin Town Demolition, a demolition for renovation construction service contractor business, at 16648 Polk Street NE, a parcel of certain land situated in the City of Ham Lake, Anoka County, Minnesota and which is described as follows to wit:

LOT 5, BLOCK 3 CREEKSIDE FARMS

At such hearing both written and oral comments will be heard.

DATED: December 1, 2023

Jennifer Bohr
Building and Zoning Clerk
City of Ham Lake

TTD HQ

Twin town demolition is a selective demolition for renovation contractor. We currently have approximately 30 employees. 5 are office and approximately 25 field staff. TTD works on a variety of public and private selective demolition projects all over the state every year. Averaging around 4 million in revenue.

We intend to use the new building as our base of operations. We plan to store tools and equipment at the new headquarters for mobilization of jobs by our shop employee. We have a few large box trucks that we use to support the field and many small pieces of demolition equipment that will be stored in the warehouse space. All our field staff report directly to the jobsite with the exception of the occasional employee picking up a truck to mobilize.

We don't typically have visitors and the majority of our traffic would come from our office staff mobilizing and demobilizing jobs. Our PM's and CM are typically in and out looking at projects out for bid and checking on occasion an ongoing demo project. Lastly our typical hours of operation are 7am- 5pm Monday- Friday

We hope to make Ham Lake our home to for many years and apricate your consideration.

Sincerely,

A handwritten signature in black ink, appearing to read "Nicholas Hahn". The signature is written in a cursive, flowing style with a large initial "N".

Memorandum

Date: December 6, 2023
To: Planning Commissioners
From: David A. Krugler, City Engineer 
Subject: Twin Town Demolition

Introduction:

The proposed 4,608 square-foot Twin Town Demolition building is located on the 7.21-acre Lot 5, Block 3, Creekside Farms parcel. The parcel is zoned Commercial Development Tier 2 (CD-2). A 500 scale aerial photo, a 1,000-scale zoning map and 400-scale half section maps are attached.

Discussion:

The Site and Paving Plan, Grading & Erosion Control Plan, Utility Plan, Details, SWPPP and Landscaping Plan and Lighting Plan received December 1st, the Storm Sewer Calculations received November 28th and the Architectural Plans received November 21st address prior review comments.

The drive aisle will be considered a fire access and must follow the following rules of Minnesota Fire Code 503.4 which states:

Fire apparatus access roads shall not be obstructed in any manner, including by the parking of vehicles

Minnesota Fire Code 503.2.1 further describes access as follows:

Fire apparatus access roads shall have an unobstructed width of not less than 20 feet, exclusive of shoulders.

The plans propose aggregate surface on the sides and rear of the building. Per Article 11-1851 (attached):

All surfaces upon which motor vehicles will be parked or driven, and all areas in which pedestrians will be walking from point to point shall be surfaced with asphalt or concrete, to specifications established by the City's Engineer

The aggregate surface areas are prohibited from being used by licensed vehicles.

Twin Town Demolition anticipates the maximum occupancy of 12 employees, and 12 parking stalls are shown. Per the Architectural Plans, the building is rated for an maximum occupancy of 16 employees. Proof of parking for four additional stalls, along with a sidewalk, are shown on the Site and Paving Plan to the rear of the building for future development for compliance with the Minnesota Building Code. Utilization of any of the rear parking stalls will require sidewalk construction and paving.

Landscaping in commercially zoned areas is to be per Article 11-1800 of City Code (attached). The attached Landscape Plan shows proposed tree screening to the north, south and west of the proposed building. Per the attached zoning map, the parcel to the southwest is zoned Rural Single Family Residential (R-A). Per Article 11-1853 (A) (attached):

Where property lines are adjacent to residential areas, a planting screen of conifers shall be required, of sufficient size and proximity to provide an intermingled screen within five years

The Landscape Plan also shows seven proposed trees to be planted along Polk Street. Per Article 11-1853(B) of the City code, decorative trees shall be planted along the right of way lines of adjacent public roadways. 11-1860 allows for case-by-case evaluation for landscape approval and “strict adherence to the remaining provisions of Article 11-1800 may be unnecessary where size, spatial relationships, topography or other physical features render a given landscaping plan aesthetically acceptable, and departures from the strict observance of the elements of Article 11-1800 shall not be considered variances requiring a showing of physical hardship. Conversely, an applicant shall be expected to meet the general spirit of this article in establishing an aesthetically pleasing landscaping plan”. A determination needs to be made as to whether the proposed landscaping is adequate where adjacent to R-A zoning and to Polk Street right-of-way or if additional screening is required.

Twin Town Demolition plans were conditionally approved by the Coon Creek Watershed District (CCWD) Board of Managers at their November 13th meeting. The Notice of Application Status is attached. A CCWD permit is required before grading operations can commence.

Recommendation:

It is recommended that the Twin Town Demolition plans be recommended for approval, including the determination if the proposed screening is adequate.

Meeting Date: December 11, 2023

CITY OF HAM LAKE
STAFF REPORT

To: Members of the Planning Commission

From: Mark Jones, Building and Zoning Official

Subject: Twin Town Demolition requesting Site Plan Approval to build a 4,608 square foot office/warehouse building and a Conditional Use Permit to operate a demolition for renovation construction service contractor business at 16648 Polk Street NE

Introduction/Discussion:

Twin Town Demolition, a selective interior demolition for renovation business, is owned by Mr. Nicholas Holm. Mr. Holm is requesting site plan approval, and approval to operate under a Conditional Use Permit, at 16648 Polk Street NE. The business currently has 30 employees, 5 of which work out of the office and 25 that primarily work off-site. Twin Town Demolition's regular hours of operation are 7:00 am to 5:00 pm Monday through Friday. Mr. Holm has stated the majority of the company's commercial vehicles are taken home by employees. A few box trucks, a pickup and trailer and possibly a skid steer would be stored on-site. When speaking with Mr. Holm, he has stated he hopes to expand the business in the future and purchase some excavators. City Code requires all outside storage to be screened. Article 9-220.1(2)(bb), Standards Common to All Mercantile Districts, Permitted Outside Storage, Aesthetically Screened Outside Storage is permitted outside storage if used as a condition of approval of any site plan, Conditional Use Permit or Temporary Conditional Use Permit on any CD-1 or CD-2 parcel in connection with the new construction of a main commercial building on the parcel. Aesthetically Screened Outside Storage is storage defined as inventory behind an opaque barrier constructed of masonry or brick, attached to and matching or complementary to the main building. No object shall be stored inside of such a barrier if the object protrudes above the height of the barrier. Per Article 9-220.1(1)(jj) and 9-220.1(2)(gg), Screened Outside Storage, could be a semi-opaque barrier of vegetation that substantially conceals the storage from outside view which is permitted if a condition of approval of any site plan, Conditional Use Permit, on any CD-1 or CD-2 parcel involving pre-existing main buildings or structures. The landscape plan for Twin Town Demolition indicates screening will be provided by spruce trees on the north, west and south sides of the property. In the past, other material and/or vegetation, other than masonry or brick, has been allowed for screening in the CD-1 and CD-2 zoning districts. The Planning Commission will need to determine if the proposed planting of spruce trees should be allowed for screening outside storage and adequately provides

screening to abutting residential properties. R-M, Manufactured Home zoning to the north and R-A, Rural Residential Single Family zoning to the west.

Recommendation:

I recommend approval of the Conditional Use Permit with the following conditions:

1. The surfaces upon which motor vehicles will be parked or driven, and all areas in which pedestrians will be walking from point to point, shall be surfaced with asphalt or concrete, to specifications established by the City's Engineer per Article 11-1851; all parking lots, drives and surfaces upon which the general public and employees shall have access shall be paved according to specifications to be established by the City's Engineer per Article 9-220.1.a.
2. All outside storage is to be on a Class V surface screened by a code compliant fence that is at least eight-feet high to conceal storage from outside view. If planting of conifers trees for screening shall be allowed, the conifers must be of sufficient size to provide an intermingled screen of eight feet within five years to conceal storage from outside view. Conifer trees are to be maintained, meaning if a tree needs to be replaced, the replacement tree's height shall be the same height, or average tree height, of the majority of the trees providing screening at the time of replacement.
3. Hours of operation are to be between 7:01 am and 10:00 pm
4. Complying with all City and State Codes if any vehicles are stored inside of the building.
5. Storage of refuse containers must comply with Article 9-220.1.f.

I recommend approval of the site plan with the following conditions:

1. All surfaces used for customer and employee parking, and for storage of over the road vehicles, shall be asphalt or concrete, to specifications established and approved by the City Engineer.
2. The exterior finish of the building must meet CD-2 building standards.

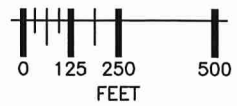
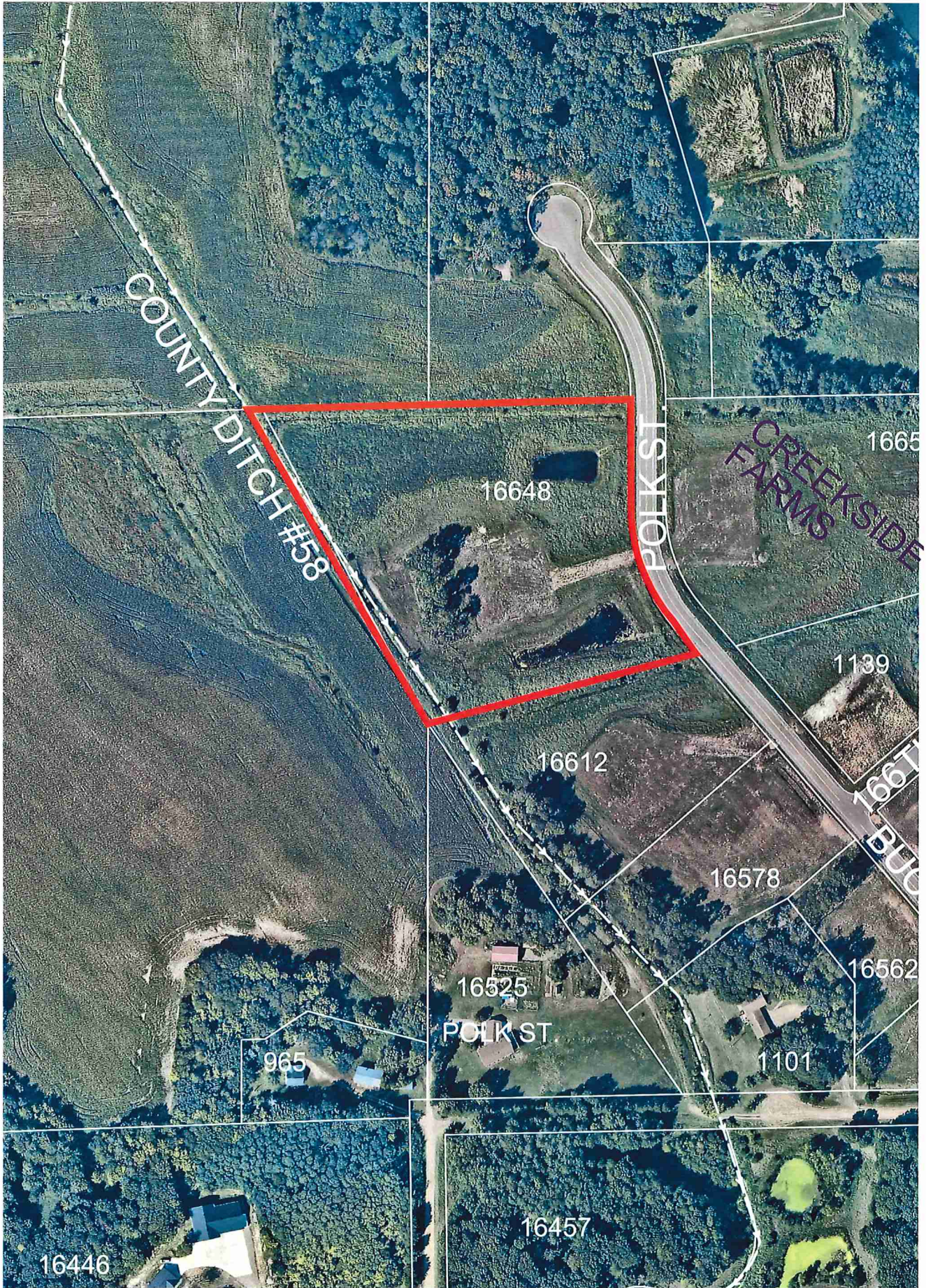

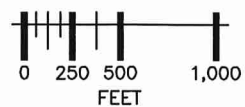
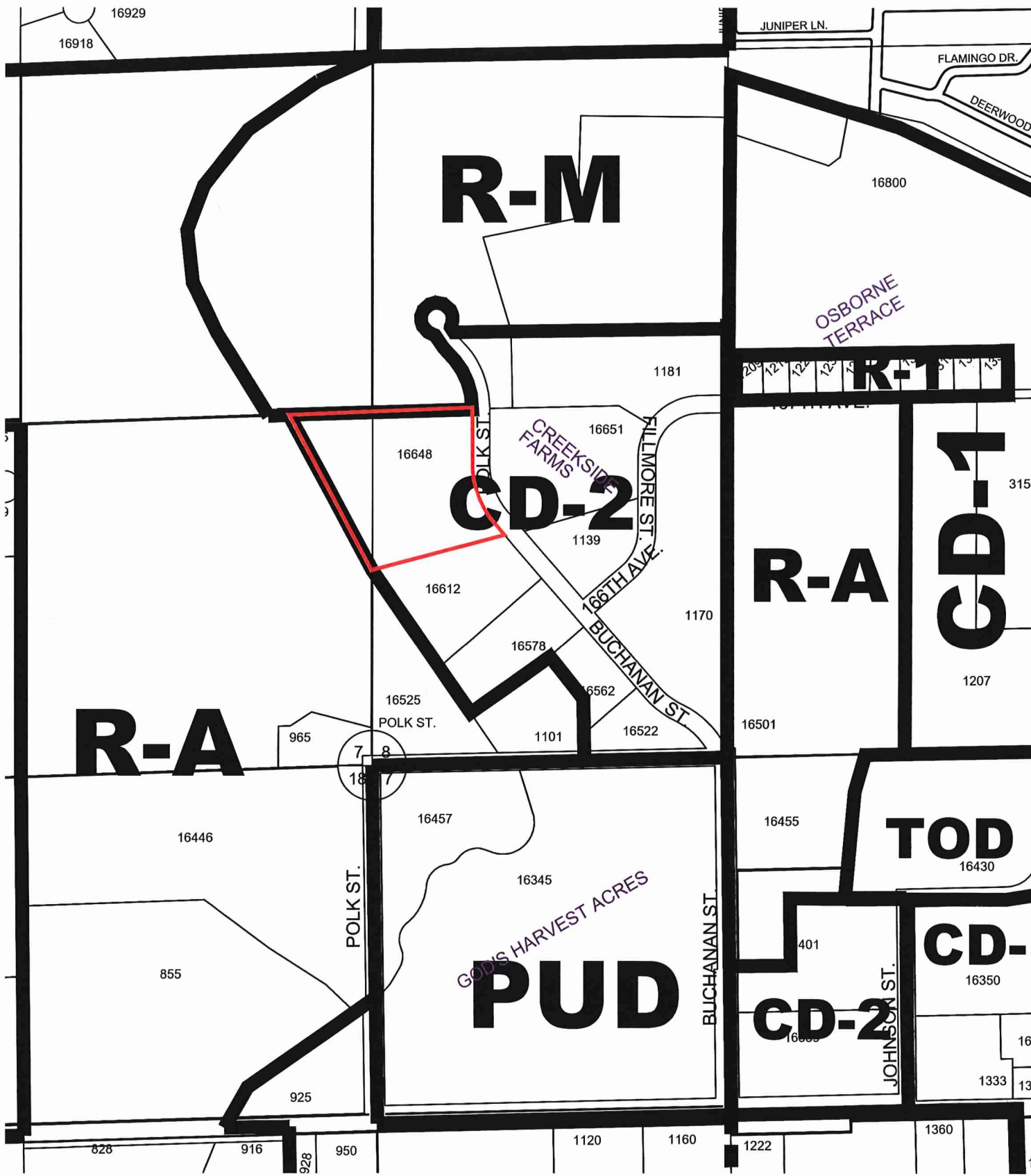

S 1/2 SECTION 8, T. 32, R. 23

CITY OF HAM LAKE

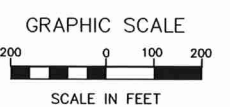
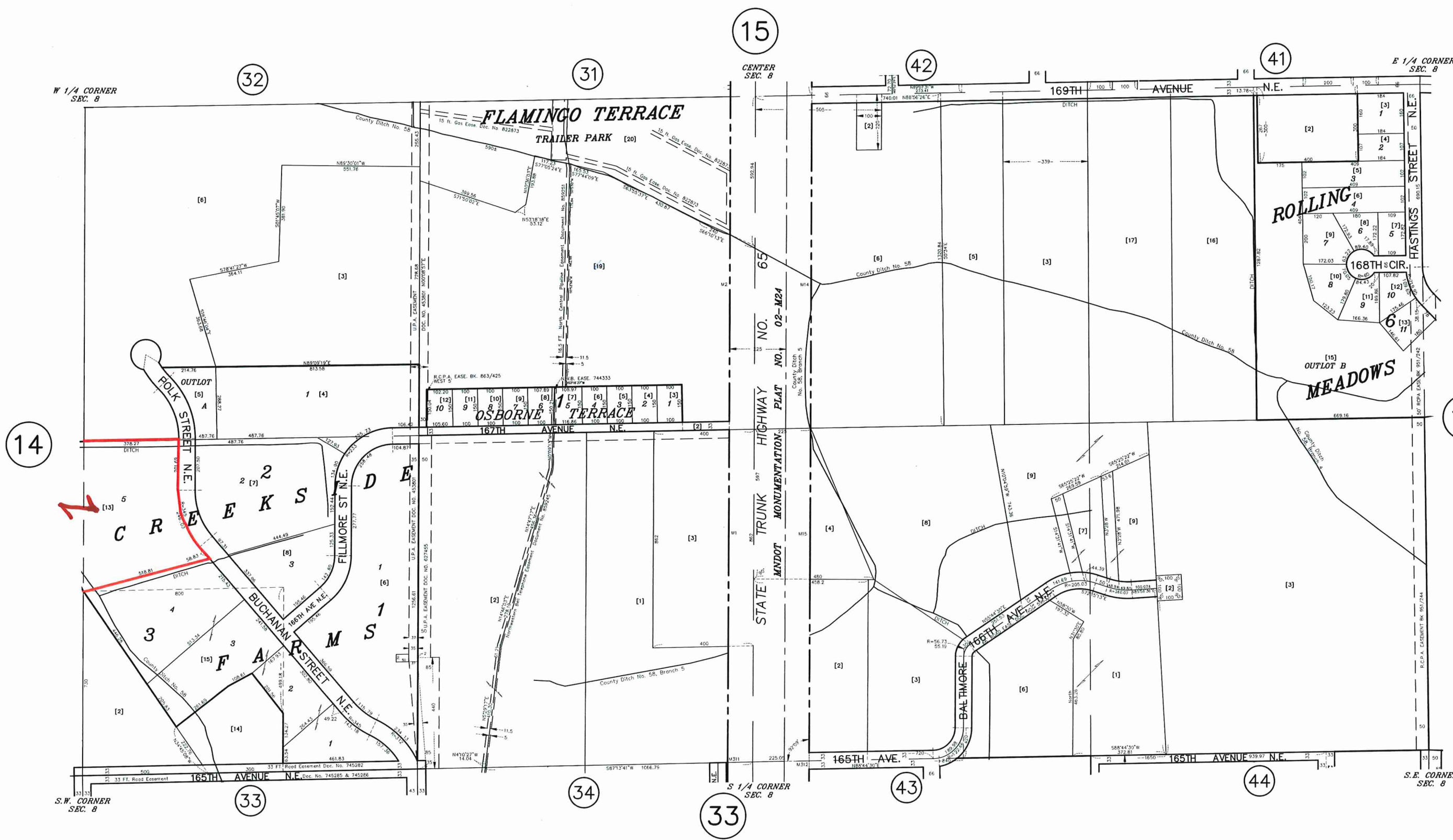

ANOKA COUNTY
SURVEYOR'S OFFICE
ROOM 224
2100 3RD AVENUE
ANOKA, MN 55303
(763) 324-3200

QUARTER QUARTER INDEX

22	21	12	11
23	24	13	14
} NORTH HALF OF SECTION			
32	31	42	41
33	34	43	44
} SOUTH HALF OF SECTION			

PROPERTY IDENTIFICATION NUMBER

Section Number	Township Number	Range Number	Quarter Number	Specific Parcel
XX	XX	XX	XX	XXXX

SPECIFIC PARCEL NUMBERS ARE IN BRACKETS: [1]
EXAMPLE OF PIN NUMBER: 08-32-23-43-0003

THIS IS A COMPILATION OF RECORDS AS THEY APPEAR IN THE ANOKA COUNTY OFFICES AFFECTING THE AREA SHOWN. THIS DRAWING IS TO BE USED ONLY FOR REFERENCE PURPOSES AND THE COUNTY IS NOT RESPONSIBLE FOR ANY INACCURACIES HEREIN CONTAINED.

S 1/2 SECTION 7, T. 32, R. 23

CITY OF HAM LAKE

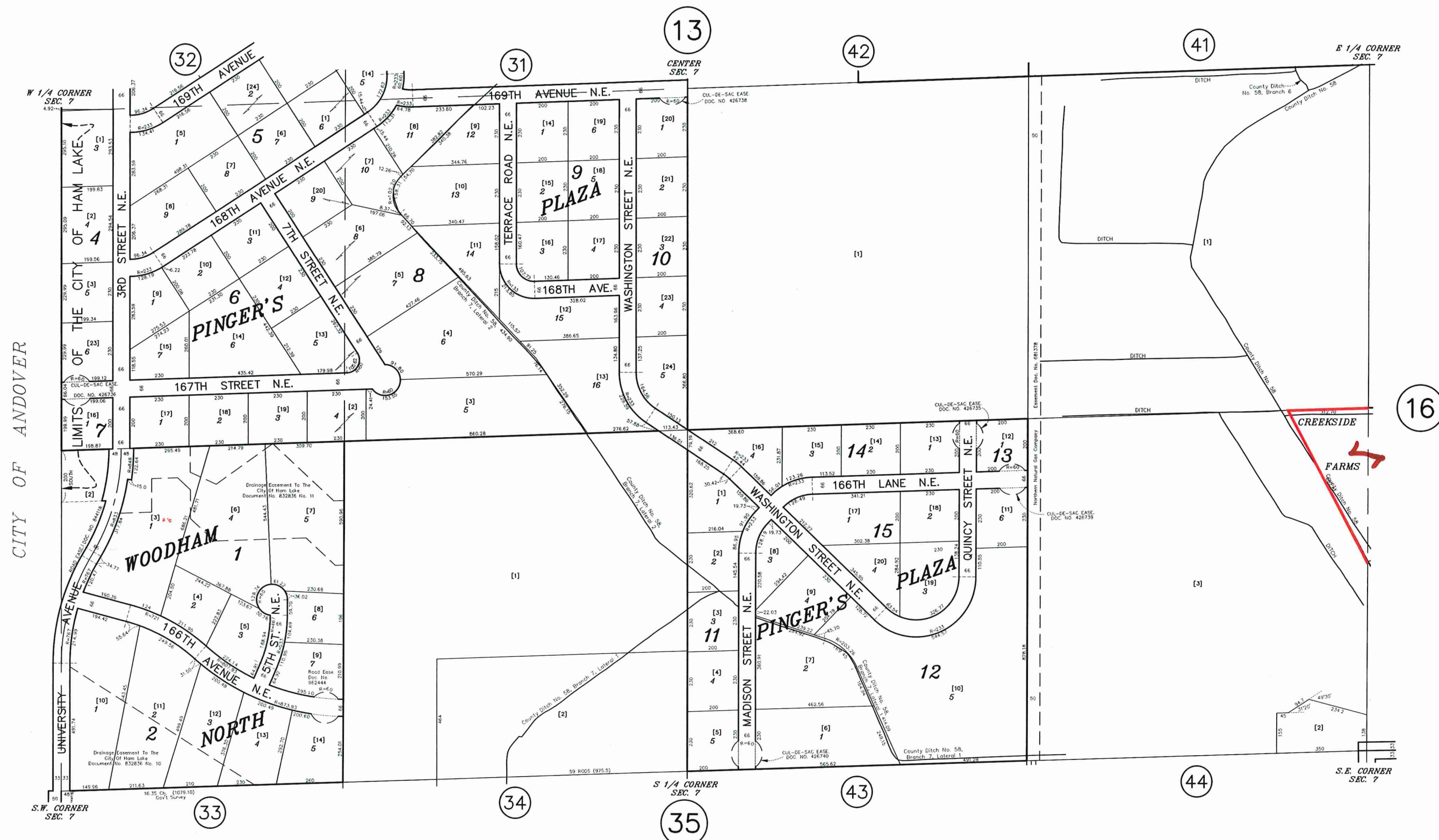

CITY OF ANDOVER

LIMITS OF THE CITY OF HAM LAKE

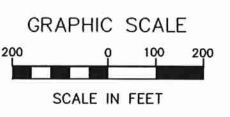

ANOKA COUNTY
SURVEYOR'S OFFICE
ROOM 224
2100 3RD AVENUE
ANOKA, MN 55303
(763) 324-3200

QUARTER QUARTER INDEX

22	21	12	11
23	24	13	14
32	31	42	41
33	34	43	44

NORTH HALF OF SECTION

SOUTH HALF OF SECTION

PROPERTY IDENTIFICATION NUMBER

Section Number	Township Number	Range Number	Quarter	Specific Parcel
XX	XX	XX	XX	XXXX

SPECIFIC PARCEL NUMBERS ARE IN BRACKETS: [1]
EXAMPLE OF PIN NUMBER: 07-32-23-43-0007

THIS IS A COMPILATION OF RECORDS AS THEY APPEAR IN THE ANOKA COUNTY OFFICES AFFECTING THE AREA SHOWN. THIS DRAWING IS TO BE USED ONLY FOR REFERENCE PURPOSES AND THE COUNTY IS NOT RESPONSIBLE FOR ANY INACCURACIES HEREIN CONTAINED.

VICINITY MAP

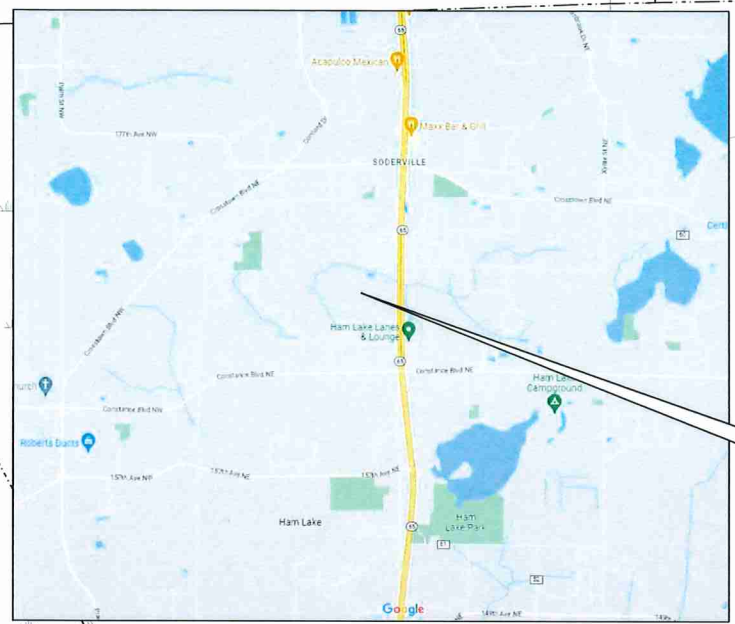

Twin Town Demolition
L5 BL 3 Creekside Farms
Ham Lake, MN 55304

SYMBOL LEGEND

- NEW BITUMINOUS PAVEMENT
SEE DETAIL 1/C400
- NEW CONCRETE PAVEMENT
SEE DETAIL 2/C400
- NEW GRAVEL
SEE DETAIL 5/C400
- NEW STOOP
SEE ARCHITECTURAL/STRUCTURAL

NOTE: THE CONCRETE JOINTS ARE SHOWN ONLY FOR GENERAL REFERENCE TO SIGNIFY CONCRETE PAVEMENT. ACTUAL JOINTS SHALL BE CONSTRUCTED PER PROJECT SPECIFICATIONS.

GENERAL

- PROPERTY LINE
- EASEMENT LINE
- RIGHT-OF-WAY LINE
- SETBACK LINE
- PROPOSED CATCH BASIN
- PROPOSED WELL
- PROPOSED SEPTIC TANK
- HOLDING TANK
- APRON/FES

KEY NOTES

- 1 NEW B612 CONCRETE CURB, SEE DETAIL 3/C400
- 2 NEW FLUSH CURB, SEE DETAIL 4/C400
- 3 NEW PARKING SIGN AND POST, SEE DETAIL 6/C400
A: ADA PARKING
B: ADA ACCESS AISLE
- 4 NEW RETAINING WALL, SEE DETAIL 7/C401
- 5 NEW 15' x 15' DUMPSTER ENCLOSURE, SEE ARCH
- 6 NEW CONCRETE BOLLARD. COORDINATE LOCATIONS WITH GARAGE DOOR OPENINGS. SEE DETAIL 8/C401
- 7 MAXIMUM 2% GRADE IN ACCESSIBLE PARKING AREA

SITE INFORMATION:

SITE ZONING: CD-2	
BUILDING AREA	
1ST FLOOR:	4,608 SF
MEZZANINE:	845 SF
PAVEMENT/CL 5 AREA: 22,767 SF	
PROPERTY AREA	314,032 SF
PROPOSED IMPERVIOUS AREA	26,602 SF
MAX. ALLOWABLE IMPERVIOUS	26,612 SF*

*MAXIMUM ALLOWABLE IMPERVIOUS WAS DETERMINED FROM THE CREEKSIDE FARMS DEVELOPMENT PROJECT (CCWD 21-033). EACH STORMWATER POND IN THE DEVELOPMENT WAS DESIGNED TO ACCOMMODATE A MAXIMUM AREA OF IMPERVIOUS FROM EACH LOT. AS LONG AS THE PROPOSED IMPERVIOUS FROM LOT DOES NOT EXCEED THE MAXIMUM ALLOWABLE. ADDITIONAL ONSITE STORMWATER TREATMENT IS NOT REQUIRED.

Larson Engineering, Inc.
816 W. St. Germain Street
Suite 308, St. Cloud, MN 56301
320.428.5824
www.larsonengr.com

© 2023 Larson Engineering, Inc. All rights reserved.

TWIN TOWN DEMOLITION
DEMOLITION
13385 207TH AVENUE NW
ELK RIVER, MN 56330

TWIN TOWN DEMOLITION
NEW BUILDING
LOT 5, BLOCK 3, CREEKSIDE FARMS
HAM LAKE, MN

I hereby certify that this plan, specifications or report was prepared by me or under my direct supervision and that I am a duly licensed Professional Engineer under the laws of the state of Minnesota.

Thomas J. Herkenhoff
Thomas J. Herkenhoff, P.E.
Date: 12.01.23 Lic. No.: 25520

Rev	Date	Description
▲	11.28.23	CITY COMMENTS
▲	11.29.23	CITY COMMENTS

Project #: 12236155
Drawn By: KBK
Checked By: TJH
Issue Date: 12.01.23

Sheet Title:
SITE AND PAVING PLAN

Sheet:
C100

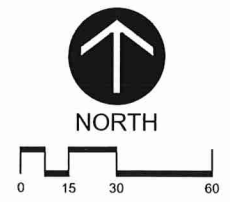

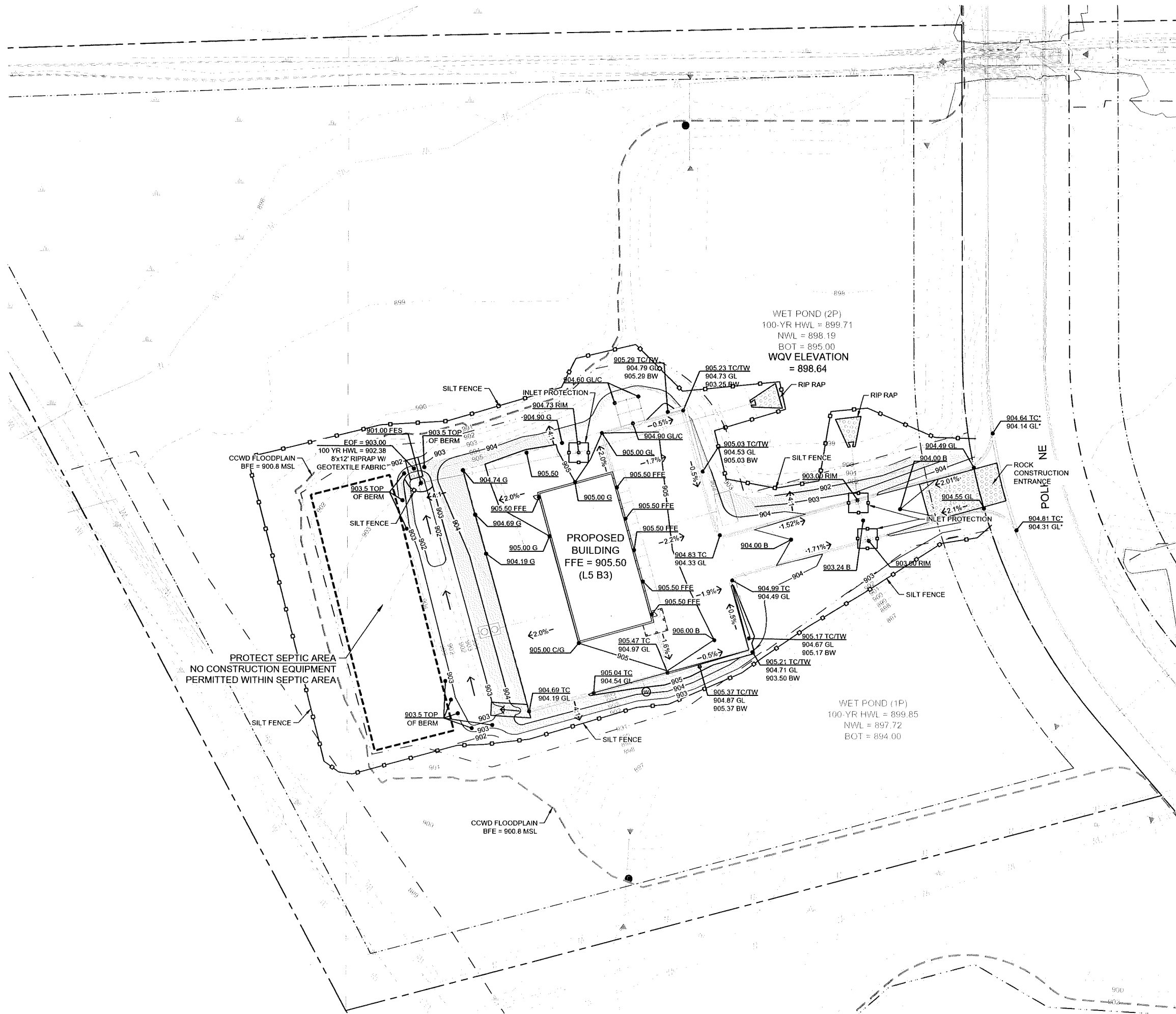

SYMBOL LEGEND

- 950 EXISTING CONTOURS
- 950 PROPOSED CONTOURS - MAJOR INTERVAL
- 949 PROPOSED CONTOURS - MINOR INTERVAL
- GRADE BREAK LINE
- GRADE SLOPE
- SILT FENCE
- RIP-RAP / ROCK CONST. ENTRANCE
SEE DETAIL 1/C401 & 4/C401
- EROSION CONTROL BLANKET
SEE DETAIL 2/C401
- INLET PROTECTION
SEE DETAIL 3/C401

- SPOT ABBREVIATIONS:**
- TC - TOP OF CURB
 - GL - GUTTER LINE
 - GO - GUTTER OUT
 - B - BITUMINOUS
 - C - CONCRETE
 - G - GROUND
 - EO - EMERGENCY OVERFLOW
 - TW - TOP OF WALL
 - BW - BOTTOM OF WALL (F/G)
 - (*) - EXISTING TO BE VERIFIED

GENERAL

- PROPERTY LINE
- EASEMENT LINE
- RIGHT-OF-WAY LINE
- SETBACK LINE
- PROPOSED CATCH BASIN
- PROPOSED WELL
- PROPOSED SEPTIC TANK
- HOLDING TANK
- APRON/FES

GRADING NOTES

1. Tree protection consisting of snow fence or safety fence installed at the drip line shall be in place prior to beginning any grading or demolition work at the site.
2. All elevations with an asterisk (*) shall be field verified. If elevations vary significantly, notify the Engineer for further instructions.
3. Grades shown in paved areas represent finish elevation.
4. All disturbed areas to receive 4" of good quality topsoil and seed.
5. All construction shall be performed in accordance with state and local standard specifications for construction.
6. See sheets C500 & C501 for SWPPP and erosion control information.
7. Maximum 2% grade in handicap accessible parking and aisle areas.
8. Stabilize soils and stockpiles within 24 hours of inactivity.

Larson Engineering, Inc.
 816 W. St. Germain Street
 Suite 308, St. Cloud, MN 56301
 320.428.5824
 www.larsonengr.com

© 2023 Larson Engineering, Inc. All rights reserved.

TWIN TOWN DEMOLITION
DEMOLITION
 13385 207TH AVENUE NW
 ELK RIVER, MN 56330

TWIN TOWN DEMOLITION
NEW BUILDING
 LOT 5, BLOCK 3, CREEKSIDE FARMS
 HAM LAKE, MN

I hereby certify that this plan, specifications or report was prepared by me or under my direct supervision and that I am a duly licensed Professional Engineer under the laws of the state of Minnesota.

Thomas J. Herkenhoff
 Thomas J. Herkenhoff, P.E.
 Date: 12.01.23 Lic. No.: 25520

Rev	Date	Description
▲	11 28 23	CITY COMMENTS
▲	11 29 23	CITY COMMENTS

Project #: 12236155
 Drawn By: KBK
 Checked By: TJH
 Issue Date: 12.01.23
 Sheet Title:

GRADING & EROSION CONTROL PLAN

Sheet:
C200

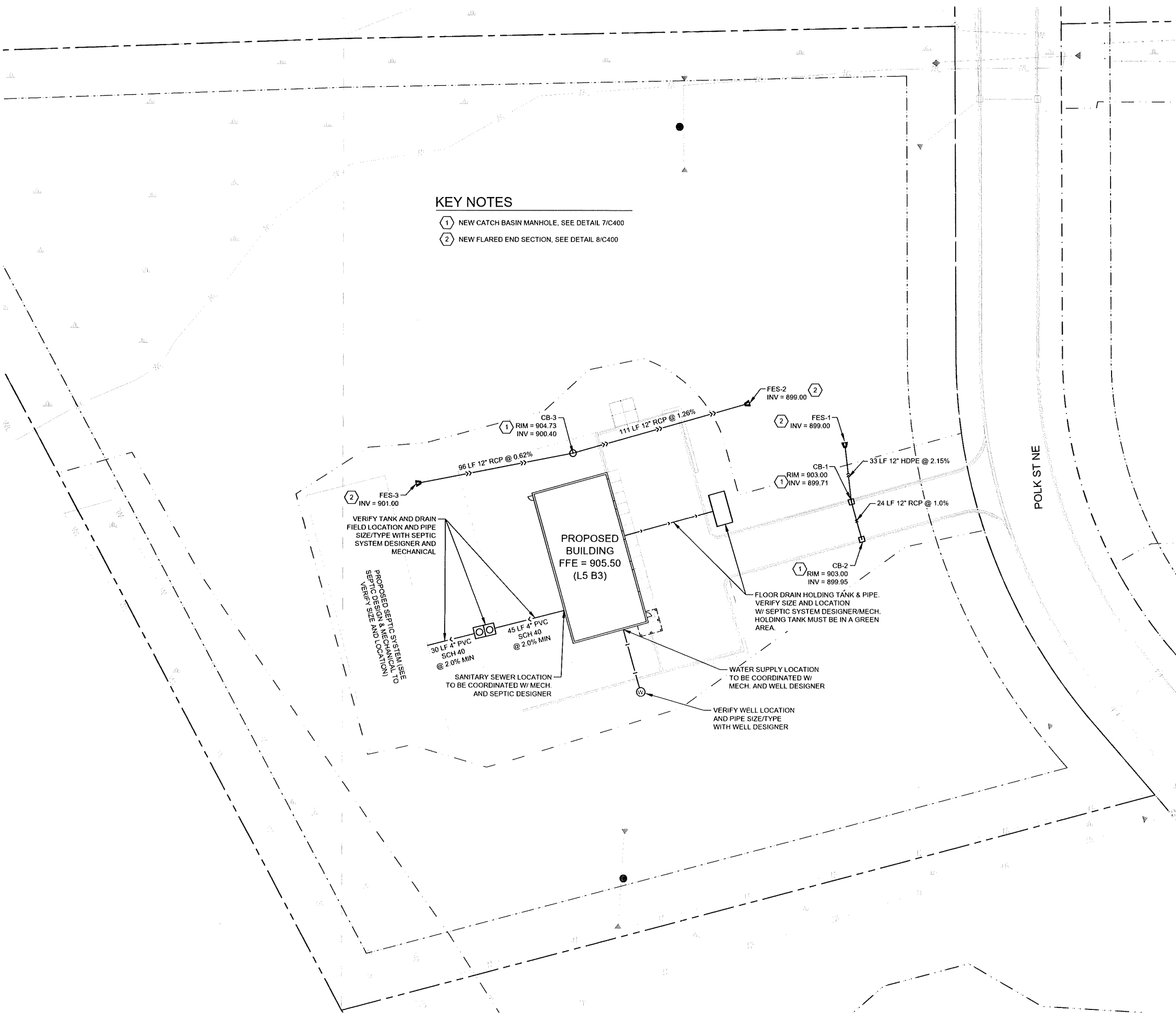

KEY NOTES

- ① NEW CATCH BASIN MANHOLE, SEE DETAIL 7/C400
- ② NEW FLARED END SECTION, SEE DETAIL 8/C400

SYMBOL LEGEND

- STORM MANHOLE
- CATCH BASIN
- CURB INLET
- ▲ FLARED END
- SANITARY MANHOLE
- ⊕ HYDRANT
- ⊗ GATE VALVE & BOX
- ⊗ WATER SHUTOFF
- ☀ LIGHT POLE
- CTY — CABLE UNDERGROUND LINE
- OE — ELECTRIC OVERHEAD LINE
- UE — ELECTRIC UNDERGROUND LINE
- FO — FIBER OPTIC UNDERGROUND LINE
- GAS — NATURAL GAS UNDERGROUND LINE
- S — SANITARY SEWER PIPE
- SS — STORM SEWER PIPE
- T — TELEPHONE UNDERGROUND LINE
- W — WATERMAIN PIPE
- DT — DRAIN TILE PIPE

GENERAL

- — — — — PROPERTY LINE
- — — — — EASEMENT LINE
- — — — — RIGHT-OF-WAY LINE
- — — — — SETBACK LINE
- PROPOSED CATCH BASIN
- PROPOSED WELL
- ⊗ PROPOSED SEPTIC TANK
- HOLDING TANK
- ▲ APRON/FES

UTILITY NOTES

1. It is the responsibility of the contractor to perform or coordinate all necessary utility connections and relocations from existing utility locations to the proposed building, as well as to all onsite amenities. These connections include but are not limited to water, sanitary sewer, cable TV, telephone, gas, electric, site lighting, etc.
2. All service connections shall be performed in accordance with state and local standard specifications for construction. Utility connections (sanitary sewer, watermain, and storm sewer) may require a permit from the City.
3. The contractor shall verify the elevations at proposed connections to existing utilities prior to any demolition or excavation.
4. The contractor shall notify all appropriate engineering departments and utility companies 72 hours prior to construction. All necessary precautions shall be made to avoid damage to existing utilities.
5. Storm sewer requires testing in accordance with Minnesota plumbing code 4714.1107 where located within 10 feet of waterlines or the building.
6. HDPE storm sewer piping shall meet ASTM F2306 and fittings shall meet ASTM D3212 joint pressure test. Installation shall meet ASTM C2321.
7. All RCP pipe shown on the plans shall be MN/DOT class 3.
8. Maintain a minimum of 7 1/2' of cover over all water lines and sanitary sewer lines. Where 7 1/2' of cover is not provided, install 2" rigid polystyrene insulation (MN/DOT 3760) with a thermal resistance of at least 5 and a compressive strength of at least 25 psi. Insulation shall be 8" wide, centered over pipe with 6" sand cushion between pipe and insulation. Where depth is less than 5', use 4" of insulation.
9. Install water lines 12" above sewers. Where the sewer is less than 12" below the water line (or above), install sewer piping of materials approved for inside building use for 10 feet on each side of the crossing.
10. All watermain piping shall be class 52 ductile iron pipe unless noted otherwise.
11. See Project Specifications for bedding requirements.
12. Pressure test and disinfect all new watermains in accordance with state and local requirements.
13. Sanitary sewer piping shall be PVC, SDR-35 for depths less than 12', PVC SDR-26 for depths between 12' and 26', and class 52 D.I.P. for depths of 26' or more.
14. A structure adjustment shall include removing and salvaging the existing casting assembly, removing existing concrete rings to the precast section. Install new rings and salvaged casting to proposed grades, cleaning casting flange by mechanical means to insure a sound surface and install an external chimney seal from casting to precast section. Chimney seals shall be Infi-Shield Uni-Band or an approved equal.

VERIFY TANK AND DRAIN FIELD LOCATION AND PIPE SIZE/TYPE WITH SEPTIC SYSTEM DESIGNER AND MECHANICAL

PROPOSED SEPTIC SYSTEM (SEE SEPTIC DESIGN & MECHANICAL) VERIFY SIZE AND LOCATION

PROPOSED BUILDING
FFE = 905.50
(L5 B3)

FLOOR DRAIN HOLDING TANK & PIPE. VERIFY SIZE AND LOCATION W/ SEPTIC SYSTEM DESIGNER/MECH. HOLDING TANK MUST BE IN A GREEN AREA.

SANITARY SEWER LOCATION TO BE COORDINATED W/ MECH. AND SEPTIC DESIGNER

WATER SUPPLY LOCATION TO BE COORDINATED W/ MECH. AND WELL DESIGNER

VERIFY WELL LOCATION AND PIPE SIZE/TYPE WITH WELL DESIGNER

Larson Engineering, Inc.
816 W. St. Germain Street
Suite 308 St. Cloud, MN 56301
320.428.5624
www.larsonengr.com

© 2023 Larson Engineering, Inc. All rights reserved.

TWIN TOWN DEMOLITION
DEMOLITION
13385 207TH AVENUE NW
ELK RIVER, MN 56330

TWIN TOWN DEMOLITION
NEW BUILDING
LOT 5, BLOCK 3, CREEKSIDE FARMS
HAM LAKE, MN

I hereby certify that this plan, specifications or report was prepared by me or under my direct supervision and that I am a duly licensed Professional Engineer under the laws of the state of Minnesota.

Thomas J. Herkenhoff
Thomas J. Herkenhoff, P.E.
Date: 12.01.23 Lic. No.: 25520

Rev	Date	Description
△	11 28 23	CITY COMMENTS
△	11 29 23	CITY COMMENTS

Project #: 12236155
Drawn By: KBK
Checked By: TJH
Issue Date: 12.01.23
Sheet Title:

UTILITY PLAN

Sheet:

C300

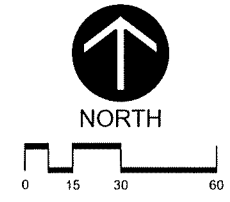

NOTE: VERIFY SECTION WITH OWNER.

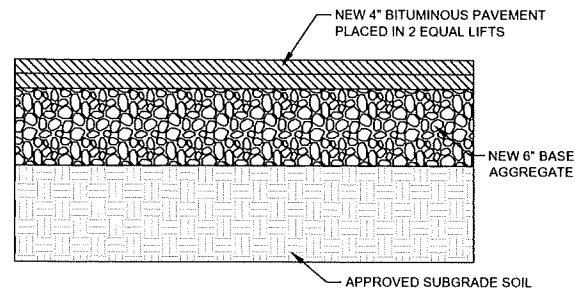

BITUMINOUS PAVEMENT SECTION

1
C400

NOT TO SCALE

NOTE: VERIFY SECTION WITH OWNER.

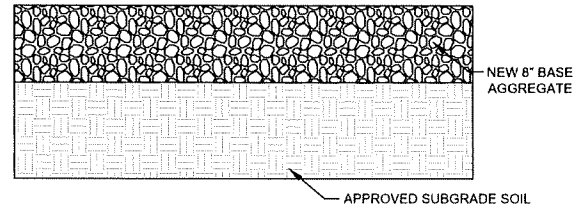

GRAVEL SECTION

5
C400

NOT TO SCALE

NOTE: VERIFY SECTION WITH OWNER.

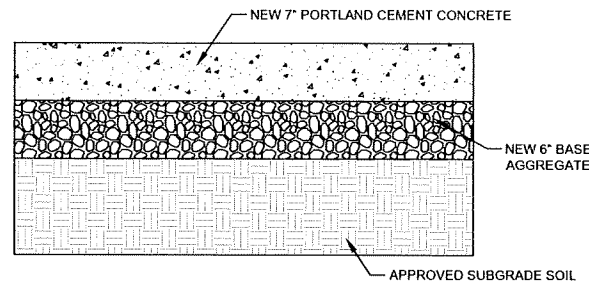

CONCRETE CONSTRUCTION DETAIL

2
C400

NOT TO SCALE

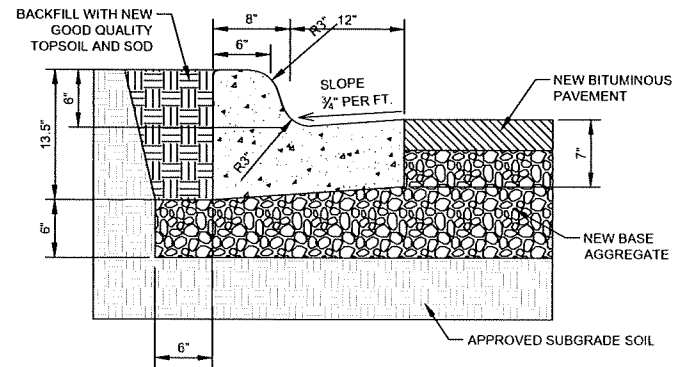

B612 CONCRETE CURB & GUTTER DETAIL

3
C400

NOT TO SCALE

NOTE: VERIFY SECTION WITH OWNER.

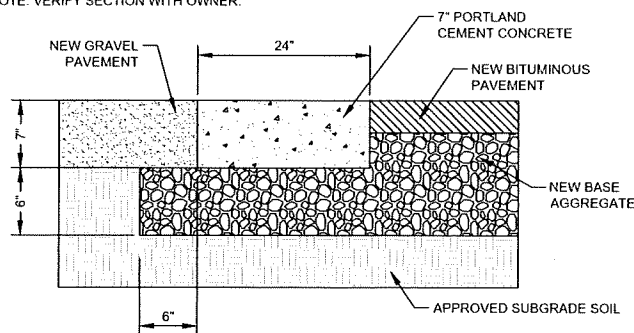

FLUSH CURB DETAIL

4
C400

NOT TO SCALE

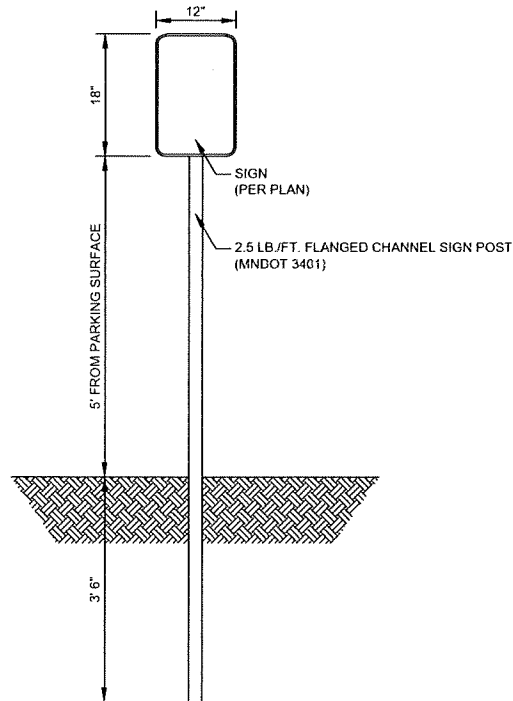
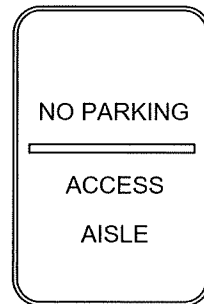
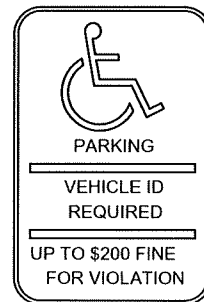

- NOTES:
1. ALL SIGNS TO BE INSTALLED IN ACCORDANCE WITH MMUTCD AND MNDOT CURRENT STANDARD SIGNS MANUAL.
 2. ALL SIGNS SHALL BE REVIEWED AND APPROVED BY OWNER/ENGINEER PRIOR TO CONSTRUCTION.
 3. SIGN POSTS TO BE 6" BEHIND THE BACK OF CURB, UNLESS OTHERWISE DIRECTED.
 4. SHARE POST WHERE APPLICABLE.
 5. SIGNS WITHIN CONCRETE SIDEWALKS SHALL BE SURFACE MOUNTED WITH APPROVED BREAK-AWAY DEVICES.

PARKING SIGN AND POST DETAIL

6
C400

NOT TO SCALE

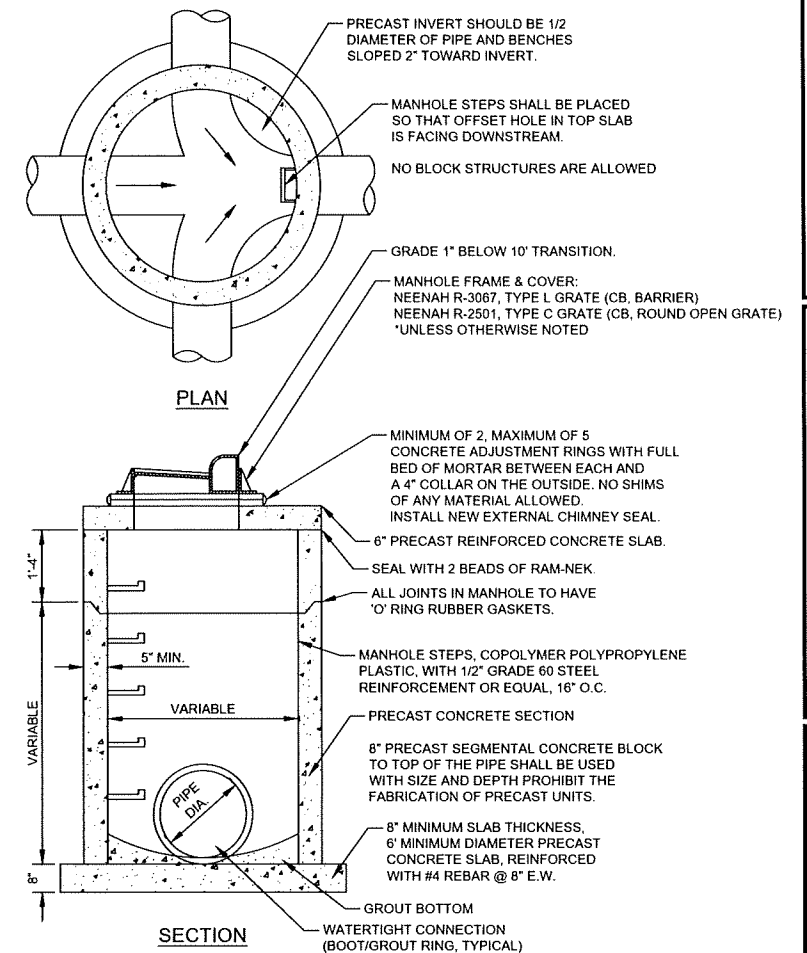

CATCH BASIN MANHOLE DETAIL

7
C400

NOT TO SCALE

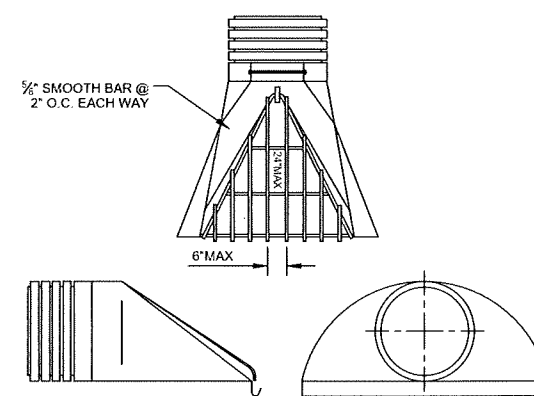

PROVIDE 3 CLIPS TO FASTEN TRASH GUARD TO F.E.S. HOT DIP GALVANIZE AFTER FABRICATION.

FLARED END SECTION DETAIL

8
C400

NOT TO SCALE

Larson Engineering, Inc.
 816 W. St. Germain Street
 Suite 308, St. Cloud, MN 56301
 320.428.5624
 www.larsonengr.com

© 2023 Larson Engineering, Inc. All rights reserved.

TWIN TOWN DEMOLITION
DEMOLITION
 13385 207TH AVENUE NW
 ELK RIVER, MN 56330

Client:

TWIN TOWN DEMOLITION
NEW BUILDING
 LOT 5, BLOCK 3, CREEKSIDE FARMS
 HAM LAKE, MN

Project Title:

I hereby certify that this plan, specifications or report was prepared by me or under my direct supervision and that I am a duly licensed Professional Engineer under the laws of the state of Minnesota.

Thomas J. Herkenhoff
 Thomas J. Herkenhoff, P.E.

Date: 12.01.23 Lic. No.: 25520

Rev	Date	Description
1	11.28.23	CITY COMMENTS
2	11.29.23	CITY COMMENTS

Project #: 12236155
 Drawn By: KBK
 Checked By: TJH
 Issue Date: 12.01.23

Sheet Title:

DETAILS

Sheet:

C400

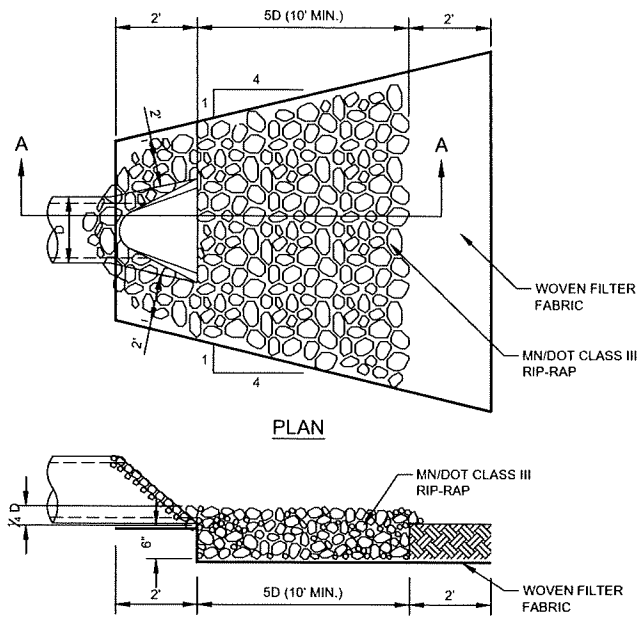

NOTE:
FW300 MIRAFI FABRIC OR EQUAL

1 RIP-RAP AT OUTLETS
C401 NOT TO SCALE

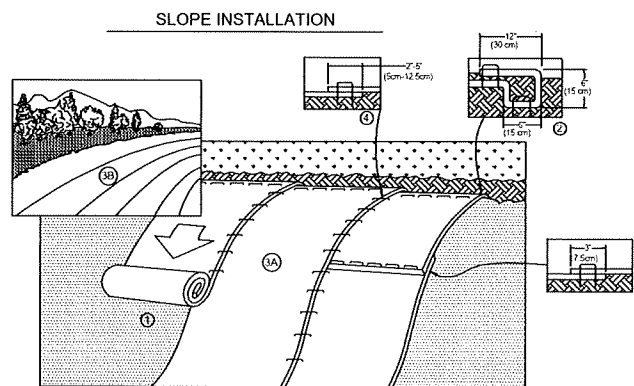

FILTER AREA	6.5 FT ²
OVERFLOW AREA	0.6 FT ²
MAXIMUM OVERFLOW RATE (@ 7" HEAD)	3.00 CFS
MAXIMUM OVERFLOW RATE (@ 13" HEAD)	4.00 CFS
BASKET WEIGHT (EMPTY)	1 LB
BASKET WEIGHT (FULL APPROX.)	70 LBS

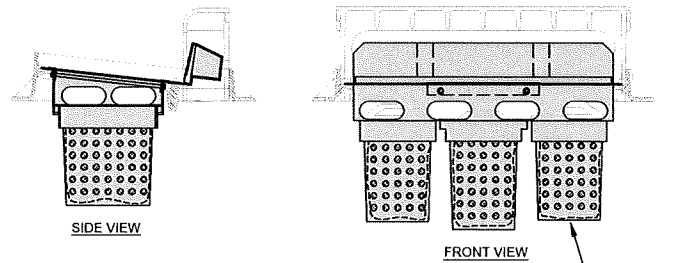

3 INFRSAFE INLET PROTECTION DEVICE (OR EQ.)
C401 NOT TO SCALE

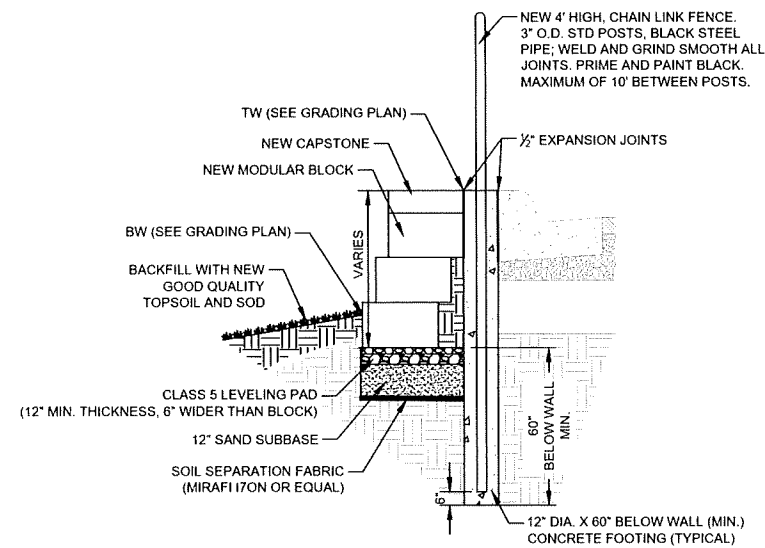

NOTES:
1. WALL TO BE DESIGNED/INSTALLED PER MANUFACTURER'S RECOMMENDATIONS.
2. WALL TYPE, COLOR, TEXTURE TO BE SELECTED BY ARCHITECT.
3. UNDER NEW FENCE, INSTALL 12" WIDE BY 6" THICK CONCRETE MAINTENANCE STRIP.

7 RETAINING WALL AND FENCE DETAIL
C401 NOT TO SCALE

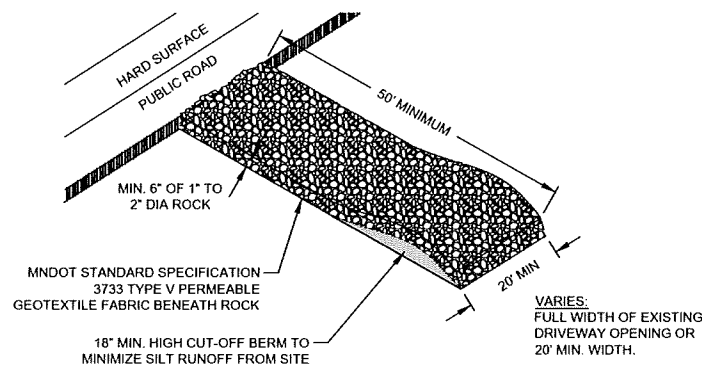

4 ROCK CONSTRUCTION ENTRANCE
C401 NOT TO SCALE

- PREPARE SOIL BEFORE INSTALLING ROLLED EROSION CONTROL PRODUCTS (RECP'S). INCLUDING ANY NECESSARY APPLICATION OF LIME, FERTILIZER, AND SEED.
NOTE: WHEN USING CELL-O-SEED DO NOT SEED PREPARED AREA. CELL-O-SEED MUST BE INSTALLED WITH PAPER SIDE DOWN.
- BEGIN AT THE TOP OF THE SLOPE BY ANCHORING THE RECP'S VIA 6" (15 CM) DEEP X 6" (15 CM) WIDE TRENCH WITH APPROXIMATELY 12" (30 CM) OF RECP'S EXTENDED BEYOND THE UP-SLOPE PORTION OF THE TRENCH. ANCHOR THE RECP'S WITH A ROW OF STAPLES/STAKES APPROXIMATELY 12" (30 CM) APART IN THE BOTTOM OF THE TRENCH. BACKFILL AND COMPACT THE TRENCH AFTER STAPLING. APPLY SEED TO COMPACTED SOIL AND FOLD RECP'S 12" (30 CM) PORTION OF RECP'S BACK OVER SEED AND COMPACTED SOIL. SECURE RECP'S OVER COMPACTED SOIL WITH A ROW OF STAPLES/STAKES SPACED APPROXIMATELY 12" (30 CM) APART ACROSS THE WIDTH OF THE RECP'S.
- ROLL THE RECP'S (A) DOWN OR (B) HORIZONTALLY ACROSS THE SLOPE. RECP'S WILL UNROLL WITH APPROPRIATE SIDE AGAINST THE SOIL SURFACE. ALL RECP'S MUST BE SECURELY FASTENED TO SOIL SURFACE BY PLACING STAPLES/STAKES IN APPROPRIATE LOCATIONS AS SHOWN IN THE STAPLE PATTERN GUIDE. WHEN USING THE DOT SYSTEM, STAPLES/STAKES SHOULD BE PLACED THROUGH EACH OF THE COLORED DOTS CORRESPONDING TO THE APPROPRIATE STAPLE PATTERN.
- THE EDGES OF PARALLEL RECP'S MUST BE STAPLED WITH APPROXIMATELY 2" - 5" (5 CM - 12.5 CM) OVERLAP DEPENDING ON RECP'S TYPE.
- CONSECUTIVE RECP'S SPICED DOWN THE SLOPE MUST BE PLACED END OVER END (SHINGLE STYLE) WITH AN APPROXIMATE 3" (7.5 CM) OVERLAP. STAPLE THROUGH OVERLAPPED AREA, APPROXIMATELY 12" (30 CM) APART ACROSS ENTIRE RECP'S WIDTH.
NOTE:
*IN LOOSE SOIL CONDITIONS, THE USE OF STAPLE OR STAKE LENGTHS GREATER THAN 6" (15 CM) MAY BE NECESSARY TO PROPERLY SECURE THE RECP'S.



Category 4 Erosion Control Blanket:
North American Green S150 erosion control blanket or approved equal.
Top Net: Polypropylene, 1.5 lbs/1,000 ft² (0.73 kg/100 m²) approx. wt.
Bottom Net: Polypropylene, 1.5 lbs/1,000 ft² (0.73 kg/100 m²) approx. wt.
Straw Fiber: 0.50 LBS/YD² (0.27 KG/M²)
Thread: Photodegradable

Staples/Anchors:
The type of anchors used to secure the blanket to the ground shall be Steel wire 11 Gauge 1" wide x 8" long.

2 EROSION CONTROL BLANKET
C401 NOT TO SCALE

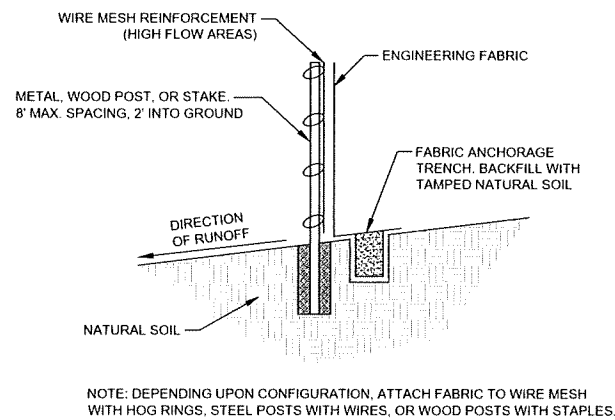

NOTE: DEPENDING UPON CONFIGURATION, ATTACH FABRIC TO WIRE MESH WITH HOG RINGS, STEEL POSTS WITH WIRES, OR WOOD POSTS WITH STAPLES.

5 SILT FENCE INSTALLATION DETAIL
C401 NOT TO SCALE

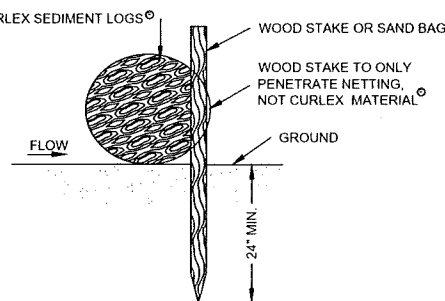

NOTES:
1. STAKE OR SAND BAG SPACING SHALL BE 2 FEET O.C.

6 SEDIMENT LOG DETAIL
C401 NOT TO SCALE

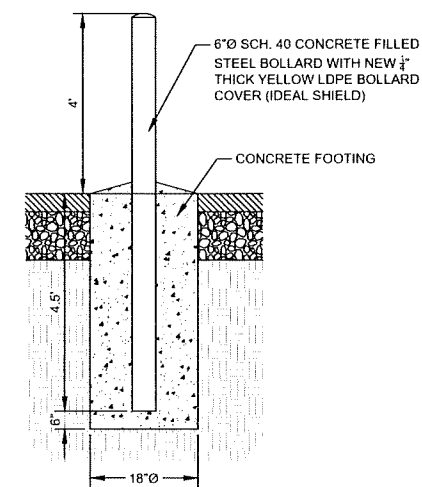

8 BOLLARD DETAIL
C401 NOT TO SCALE

TWIN TOWN
DEMOLITION

TWIN TOWN DEMOLITION
NEW BUILDING

LOT 5, BLOCK 3, CREEKSIDE FARMS
HAM LAKE, MN

Client:

Project Title:

I hereby certify that this plan, specifications or report was prepared by me or under my direct supervision and that I am a duly licensed Professional Engineer under the laws of the state of Minnesota.

Thomas J. Herkenhoff

Thomas J. Herkenhoff, P.E.

Date: 12.01.23 Lic. No.: 25520

Rev	Date	Description
1	11.28.23	CITY COMMENTS
2	11.29.23	CITY COMMENTS

Project #: 12236155
Drawn By: KBK
Checked By: TJH
Issue Date: 12.01.23

Sheet Title:

DETAILS

Sheet:

C401

PROJECT SPECIFIC SWPPP INFORMATION:

I. GENERAL CONSTRUCTION ACTIVITY INFORMATION

PROJECT NAME: TWIN TOWN DEMOLITION
PROJECT LOCATION: 16648 POLK ST NE
HAM LAKE, MN 55304

PROJECT CONTACTS

OWNER: NICK HOLM, 612.267.0461
TWIN TOWN DEMOLITION
13385 207TH AVE NW
ELK RIVER, MN 55330

ENGINEER: LARSON ENGINEERING, INC.
3524 LABORE ROAD
WHITE BEAR LAKE, MN 55110
CONTACT: T. J. ROSE, P.E., 651-481-9120
TROSE@LARSONENGR.COM

CONTRACTOR: TBD

CONTACT:
PHONE:

CITY WHERE WORK WILL TAKE PLACE: HAM LAKE, MN
COUNTY WHERE WORK WILL TAKE PLACE: ANOKA

LATITUDE/LONGITUDE OF APPROXIMATE CENTROID OF PROJECT: 45° 16' 21" N, 93° 14' 42" W

PROJECT TYPE (CIRCLE ONE): RESIDENTIAL COMMERCIAL/INDUSTRIAL

ROAD CONSTRUCTION: RESIDENTIAL & ROAD CONSTRUCTION

OTHER (DESCRIBE): _____

DATES OF CONSTRUCTION (ESTIMATED):
Construction start date: 01/2024
Construction completion date: 9/2024

PROJECT DESCRIPTION:
The project will consist of the construction of a new building and parking lot. The disturbed area will be approximately 1.4 acres. The total size of the property is approximately 7.2 acres.

PROJECT LIMITS:
See the Erosion Control Plan for site disturbance limits.

SITE DISTURBANCE SUMMARY (to nearest tenth acre):

Total number of acres to be disturbed:	1.4
Pre-Construction acres of impervious:	0.0
Post-Construction acres of impervious:	0.6
Total new impervious acres:	0.6

II. RECEIVING WATERS

RECEIVING WATERS (WITHIN ONE MILE OF PROJECT PROPERTY EDGE): None

NAME OF WATER BODY	TYPE	SPECIAL WATER?	IMPAIRED WATER?
N/A			

TOTAL MAXIMUM DAILY LOAD (TMDL) WATERS:
N/A

IDENTIFY WETLAND IMPACTS:
1. Will construction result in any potential adverse impacts to wetlands, including excavation, degradation of water quality, draining, filling, permanent inundation or flooding, conversion to a stormwater pond?
No.
If yes, describe impacts and mitigation measures that were taken to address the impacts and include copies of permits or approvals from an official state wide wetland program issued specifically for this project or site:
N/A

ENVIRONMENTALLY SENSITIVE AREAS:
1. Identify adjacent public waters where the MN DNR has declared "work in water restrictions" during fish spawning timeframes:
None identified.
2. Describe any stormwater mitigation measures that will be implemented, as a result of an environmental review, endangered or threatened species review or archeological site review:
N/A

PROJECT LOCATION AND RECEIVING WATERS MAP:

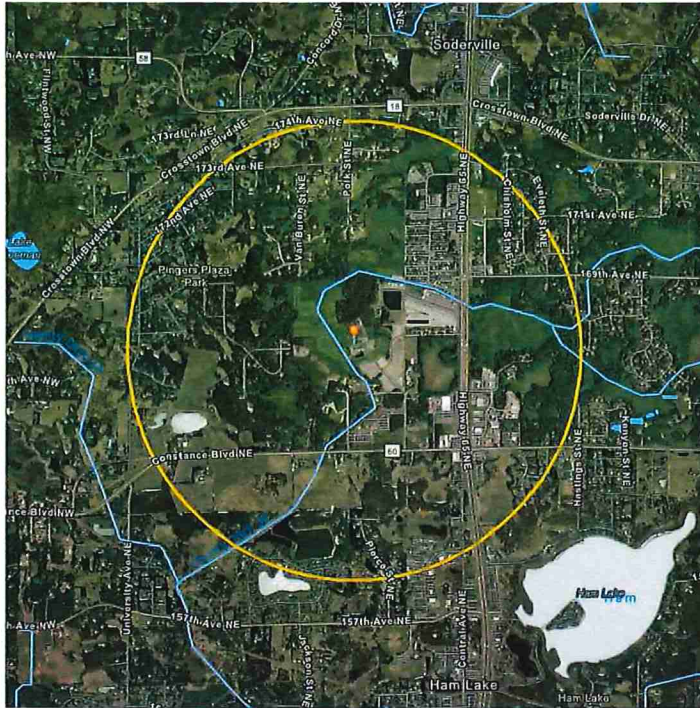

III. PROJECT PLANS AND SPECIFICATIONS

Refer to the project plans, specifications, geotechnical report, and stormwater calculations which depict various features that are relevant to this project. Such features may include, but are not limited to, the following:

- Project location and construction limits.
- Existing and final grades, including dividing lines and direction of flow for all pre and post-construction stormwater runoff drainage areas located within the project limits.
- Soil types at the site.
- Locations of impervious surfaces.
- Locations of areas not to be disturbed (e.g., buffer zones, wetlands, etc.)
- Steep slope locations.
- Locations of areas where construction will be phased to minimize duration of exposed soils.
- Locations of all temporary and permanent erosion control and sediment control best management practices (BMP's).
- Buffer zones as required in item 9.17 and 23.11 of the permit.
- Locations of potential pollution-generating activities identified in Section 12 of the permit.
- Standard details for erosion and sediment control BMP's to be installed at the site.

The anticipated erosion prevention and sediment control BMP quantities needed for the life of this project include the following. These quantities are estimated only and shall be verified by the Contractor.

BMP	Bidding Quantity	Final Quantity
Rock Construction Entrance	1 EA	_____
Silt Fence	1,030 LF	_____
Final Seeding	0.9 acres	_____
Erosion Blanket	5,570 SF	_____

TEMPORARY SEDIMENT CONTROL (SITE SPECIFIC ITEMS)

1. Is the project required to install a temporary sediment basin due to 10 or more acres draining to a common location, or 5 acres or more if the site is located within 1 mile of a special or impaired water?
No.
If yes, describe (or attach plans) showing how the basin will be designed and constructed in accordance with Section 14.
N/A
2. Will the project include dewatering, basin draining?
No.
If yes, describe measures to be used to treat/dispose of turbid or sediment-laden water and method to prevent erosion or scour of discharge points (see Section 10 of the permit):
N/A. Based on the type of work, dewatering is not anticipated.
3. Will the project include use of filters for backwash water?
No.
If yes, describe how filter backwash water will be managed on the site or properly disposed of:
N/A

PERMANENT STORMWATER MANAGEMENT (SITE SPECIFIC ITEMS)

1. Will the project result in one acre or more of new impervious surface or result in one acre or more of new impervious in total if the project is part of a larger plan of development?
No.
If yes, a water quality volume of one inch of runoff from the cumulative new impervious surfaces must be retained on site (Section 15) through infiltration unless prohibited due to one of the reasons in item 16.14 through 16.21. If infiltration is prohibited, identify other methods of stormwater treatment used (e.g. filtration, wet sedimentation basin, regional ponding, or equivalent method):
N/A
2. Attach design parameters for the planned permanent stormwater management system, including volume calculations, discharge rate calculations, construction details including basin depth, outlet configurations, location, design of pre-treatment devices, and timing for installation.
N/A

3. For infiltration systems, provide at least one soil boring, test pit, or infiltrometer test in the location of the infiltration practice for determining infiltration rates.
N/A
4. For projects that discharge to trout streams, including tributaries to trout streams, identify method of incorporating temperature controls into the permanent stormwater management system.
N/A

SEQUENCE OF CONSTRUCTION ACTIVITIES

1. Install stabilized rock construction entrances.
2. Install perimeter erosion control BMP's (silt fence, bio-logs, etc).
3. Install temporary construction fencing at areas not to be disturbed.
4. Install inlet protection throughout project area and downstream inlets.
5. Construct temporary sediment basins/traps, as necessary.
6. Stabilize denuded areas and stockpiles.
7. Place topsoil and final grading of areas to be vegetated, as needed.
8. Complete permanent stabilization including plantings, seeding, and mulch.
9. Upon completion of construction activity and satisfactory vegetation establishment, remove remaining temporary erosion and sediment control BMP's.
10. Reseed / restore any areas disturbed during BMP removal.

SEEDING NOTES AND REQUIREMENTS:

1. The Contractor is responsible to salvage and preserve existing topsoil as necessary for final stabilization. All topsoil to be salvaged and re-used shall be processed as necessary to meet project specifications.
2. Prior to final seeding, all areas to be vegetated shall be scarified/decompact and amended as specified in the plans and specifications.
3. Unless otherwise noted, all seed mixes and applications shall be in accordance with MNDOT Seeding Manual, latest edition.
4. See the project plans and specifications for seed mixtures, mulch, slope stabilization, and all other landscaping requirements.

FINAL STABILIZATION:

Ensure Final Stabilization of the site. Final Stabilization is not complete until all of the following requirements are complete:

1. All soil disturbing activities at the site have been completed and soils are stabilized by a uniform perennial vegetative cover with a density of 70 percent of its expected final growth over the entire previous surface area, or other equivalent means necessary to prevent soil erosion under erosive conditions.
2. The permanent stormwater management system is constructed and operating as designed. Temporary or permanent sedimentation basins that are to be used as permanent water quality management basins have been cleaned of any accumulated sediment. All sediment has been removed from conveyance systems and ditches are stabilized with permanent cover.
3. All temporary synthetic and structural erosion prevention and sediment control BMP's (such as silt fence, bio-logs, etc.) have been removed from the site. BMP's designed to decompose on site may be left in place.
4. Upon correction of all erosion and sediment items and achieving vegetative cover, temporary erosion prevention and sediment control BMP's will be removed and properly disposed/recycled.
5. Within 30 days of final stabilization, a notice of termination shall be submitted to the MPCA (see Permit Termination Req's).

GENERAL SWPPP NOTES:

1. The Contractor and all Subcontractors involved with construction activity that disturbs soil, or implements a pollution control measure as part of the Storm Water Pollution Prevention Plan (SWPPP) for this project, must comply with the requirements of the National Pollution Discharge Elimination System (NPDES) / State Disposal System (SDS) Program, General Permit MNR10001, Dated August 1, 2018.
2. The Contractor and all Subcontractors shall be responsible for reviewing the NPDES Permit in its entirety, to ensure that all SWPPP measures are in place and permit requirements fulfilled throughout the duration of the project.

SWPPP TRAINING (SECTION 21):

SWPPP PREPARER: COMPANY: LARSON ENGINEERING, INC.
CONTACT: T. J. ROSE, P.E., 612-231-8103
TROSE@LARSONENGR.COM

COURSE: TRAINING ENTITY: DESIGN OF CONSTRUCTION SWPPP
UNIVERSITY OF MINNESOTA
EXPIRATION: MAY 31, 2024

SWPPP CONTACT: CONTRACTOR: (TBD)
CONTACT: NAME, PHONE, EMAIL
COURSE INSTRUCTOR:
TRAINING ENTITY:
EXPIRATION:

This SWPPP was prepared by personnel certified in design of construction SWPPP's as listed above. Copies of respective certifications are available upon request. In accordance with Section 21 of the permit, the following individuals must receive training, and the content and extent of the training is commensurate with the individual's job duties and responsibilities with regard to activities covered under the permit:
a. Individuals preparing the SWPPP for the project.
b. Individuals overseeing implementation of, revising and/or amending the SWPPP, and individuals performing inspections for the project.
c. Individuals performing or supervising the installation, maintenance and repair of BMP's.

Individuals must receive training from local, state, federal agencies, professional organizations, or other entities with expertise in erosion prevention, sediment control, permanent stormwater treatment and the MN NPDES/SDS Construction Stormwater permit. Individuals shall attend a refresher-training course every three (3) years.

SWPPP IMPLEMENTATION RESPONSIBILITIES:

1. The Owner and Contractor are Permittee(s) as identified by the NPDES permit.
2. The Contractor shall be responsible for all on-site implementation of the SWPPP, including all Subcontractor activities.
3. The Contractor shall provide knowledgeable and experienced person(s) in the application, installation, and maintenance of Erosion and Sediment Control BMP's throughout the project.
4. The Contractor shall provide person(s) meeting the training requirements of the NPDES permit to conduct inspection and maintenance of all erosion prevention and sediment control BMP's in accordance with permit requirements. One of these individuals must be available for an on-site inspection within 72 hours upon request by the MPCA.
5. The Contractor shall provide training documentation for all individual(s) required by the permit. This training documentation shall be recorded in the SWPPP prior to construction, or as soon as personnel for the project have been determined. Documentation shall include:

- a. Names of personnel associated with the project required to be trained (as listed above and under Section 21 of the permit).
- b. Dates of training, name of instructor, and entity providing training.
- c. Content of training course or workshop including number of hours of training.

INSPECTIONS AND MAINTENANCE:

1. The Contractor shall provide person(s) meeting the training requirements to conduct inspection and maintenance of all erosion prevention and sediment control BMP's under this project in accordance with permit requirements.
2. An example MPCA construction stormwater checklist can be found at the link below. Note: This template inspection report does not address all aspects of the NPDES Permit. The completion of this checklist does not guarantee that all permit requirements are in compliance; it is the responsibility of the Permittee(s) to read and understand the full permit requirements.

<https://www.pca.state.mn.us/sites/default/files/wq-strm2-36.docx>

RECORDS RETENTION:

The SWPPP, including all changes/amendments, and inspections and maintenance records shall be kept on site during normal working hours by individuals who have operational control of that portion of the site.

All Owner(s) shall keep the SWPPP, along with the following additional records, on file for three (3) years after submittal of the NOT as outlined in Section 4:

- a. The Final SWPPP;
- b. Any other stormwater related permits required for the project;
- c. Records of all inspection and maintenance conducted during construction;
- d. All permanent operation and maintenance agreements that have been implemented, including all Right-Of-Way, Contracts, Covenants, and other binding requirements regarding perpetual maintenance; and
- e. All required calculations for design of the temporary and permanent stormwater management systems.

Larson Engineering, Inc.
816 W. St. Germain Street
Suite 308, St. Cloud, MN 56301
320.428.5824
www.larsonengr.com

TWIN TOWN DEMOLITION
NEW BUILDING
LOT 5, BLOCK 3, CREEKSIDE FARMS
HAM LAKE, MN

TWIN TOWN DEMOLITION
NEW BUILDING
LOT 5, BLOCK 3, CREEKSIDE FARMS
HAM LAKE, MN

I hereby certify that this plan, specifications or report was prepared by me or under my direct supervision and that I am a duly licensed Professional Engineer under the laws of the state of Minnesota.

Thomas J. Herkenhoff
Thomas J. Herkenhoff, P.E.
Date: 12.01.23 Lic. No.: 25520

Rev	Date	Description
△	11.28.23	CITY COMMENTS
△	11.29.23	CITY COMMENTS

Project #: 12236155
Drawn By: KBK
Checked By: TJH
Issue Date: 12.01.23
Sheet Title:

SWPPP
Sheet:
C500

GENERAL SWPPP REQUIREMENTS AND NOTES:

SWPPP AMENDMENTS (SECTION 6):

- One of the individuals described in item 21.2.a or 21.2.b of the permit or another qualified individual must complete all SWPPP changes. Changes involving the use of less stringent BMPs must include a justification describing how the replacement BMP is effective for the site characteristics.
- The SWPPP shall be amended to include additional or modified BMPs as necessary to correct problems identified or address situations whenever there is a change in design, construction, operation, maintenance, weather or seasonal conditions having a significant effect on the discharge of pollutants to surface waters or groundwater.
- The SWPPP shall be amended to include additional or modified BMPs as necessary to correct problems identified or address situations whenever inspections or investigations by the site owner or operator, USEPA or MPCA officials indicate the SWPPP is not effective in eliminating or significantly minimizing the ischarge of pollutants to surface waters or groundwater or the discharges are causing water quality standard exceedances (e.g., nuisance conditions as defined in Minn. R. 7050.0210, subp. 2 or the SWPPP is not consistent with the objectives of the USEPA approved TMDL.

BMP SELECTION AND INSTALLATION (SECTION 7):

- All BMPs identified in the SWPPP document and construction plans shall be selected, installed, and maintained in an appropriate and functional manner in accordance with relevant manufacturer specifications and accepted engineering practices.

TEMPORARY EROSION PREVENTION PRACTICES (SECTION 8)

- Prior to beginning any construction work at the site, locations of areas not to be disturbed must be delineated (e.g., with flags, stakes, signs, silt fence, snow fence, etc.) throughout the project site.
- Minimize the need for disturbance of portions of the project with steep slopes. For those sloped areas which must be disturbed, use techniques such as phasing and stabilization practices designed for steep slopes (e.g., slope draining and terracing).
- Stabilize all exposed soil areas (including stockpiles). Stabilization must be initiated immediately to limit soil erosion whenever any construction activity has permanently or temporarily ceased on any portion of the site and will not resume for a period exceeding 14 calendar days. Stabilization must be completed no later than 14 calendar days after the construction activity has ceased.
- Stabilization is not required on constructed base components of roads, parking lots, and similar surfaces. Stabilization is not required on temporary stockpiles without significant silt, clay or organic components (e.g., clean aggregate stockpiles, demolition concrete stockpiles, sand stockpiles) but sediment controls must be placed at the base of the stockpile.
- For Public Waters that the Minnesota Department of Natural Resources has promulgated "work in water restrictions" during specified fish spawning time frames, all exposed soil areas that are within 200 feet of the water's edge, and drain to these waters must complete the stabilization activities within 24 hours during the restriction period.
- Stabilize the normal wetted perimeter of the last 200 linear feet of temporary or permanent drainage ditches or swales that drain water from the site within 24 hours after connecting to a surface water or property edge. Stabilize remaining portions of temporary or permanent ditches or swales within 14 calendar days (or 7 days if within one mile of an identified impaired water) after connecting to a surface water or property edge and construction in that portion of the ditch temporarily or permanently ceases.
- Temporary or permanent ditches or swales being used as sediment containment systems during construction (with properly designed rock-ditch checks, bio rolls, silt dikes, etc.) do not need to be stabilized during the temporary period of use as a sediment containment system. These areas must be stabilized within 24 hours after no longer being used for as a sediment containment system.
- Applying mulch, hydromulch, tackifier, polyacrylamide or similar erosion prevention practices is not acceptable within any portion of the normal wetted perimeter of a temporary or permanent drainage ditch or swale section with a continuous slope of greater than 2 percent.
- Pipe outlets must be provided with temporary or permanent energy dissipation within 24 hours after connection to a surface water or permanent stormwater treatment system.
- Route water around unstabilized areas on the site and to reduce erosion, unless infeasible. Use erosion controls and velocity dissipation devices such as check dams, sediment traps, riprap, or grooved riprap at outlets within and along the length of any constructed stormwater conveyance channel, and at any outlet, to provide a non-erosive flow velocity, to minimize erosion of channels and their embankments, outlets, adjacent stream banks, slopes, and downstream waters during discharge conditions.
- Unless infeasible due to lack of pervious or vegetated areas, direct discharges from BMPs to vegetated areas of the site (including any natural buffers) in order to increase sediment removal and maximize stormwater infiltration. Use velocity dissipation devices if necessary to prevent erosion when directing stormwater to vegetated areas.
- Infiltration areas shall not be excavated until all upstream areas have been stabilized and/or upstream BMPs are in place to properly prevent sediment deposition. Only low impact equipment shall be allowed in infiltration areas which shall be clearly identified, staked, and marked/fenced off.
- Project phasing shall be implemented to ensure land disturbance and temporary erosion control measures can be effectively inspected and maintained throughout the duration of the project in accordance with the Inspection and Maintenance requirements of Section 11.

TEMPORARY SEDIMENT CONTROL PRACTICES (SECTION 9)

- Sediment control practices must be established on all down gradient perimeters and be located upgradient of any buffer zones. The perimeter sediment control practices must be in place before any upgradient land-disturbing activities begin. These practices shall remain in place until Final Stabilization has been established.
- If downgradient sediment controls become overloaded, based on frequent failure or excessive maintenance requirements, additional upgradient sediment control practices or redundant BMPs shall be installed to eliminate the overloading concerns. All changes shall be recorded in the SWPPP.
- Temporary or permanent drainage ditches and sediment basins designed as part of a sediment containment system (e.g., ditches with rock-check dams) require sediment control practices only as appropriate for site conditions.
- A floating silt curtain placed in the water is not an acceptable sediment control BMP except when working on a shoreline or below the waterline. Immediately after the short term construction activity (e.g., installation of rip rap along the shoreline) in that area is complete, upland perimeter control practices shall be installed if exposed soils still drain to a surface water.
- Re-install all sediment control practices that have been adjusted or removed to accommodate short-term activities such as clearing or grubbing, or passage of vehicles, immediately after the short-term activity has been completed. Complete any short-term activity that requires removal of sediment control practices as quickly as possible and re-install sediment control practices before the next precipitation event even if the short-term activity is not complete.
- All storm drain inlets must be protected by appropriate BMPs during construction until all sources with potential for discharging to the inlet have been stabilized. Inlet protection may be removed for a particular inlet if a specific safety concern (street flooding/freezing) has been identified by the Permittee(s) or the jurisdictional authority (e.g., city/county/township/MnDOT engineer).The Permittee(s) must document the need for removal in the SWPPP.
- Temporary soil stockpiles must have silt fence or other effective sediment controls, and cannot be placed in any natural buffers or surface waters, including stormwater conveyances such as curb and gutter systems, or conduits and ditches unless there is a bypass in place for the stormwater.
- Where vehicle traffic leaves any part of the site (or onto paved roads within the site) install a vehicle tracking BMP to minimize the track out of sediment from the construction site. Examples of vehicle tracking BMPs include (but are not limited to) rock pads, mud mats, slash mulch, concrete or steel wash racks, or equivalent systems. Use street sweeping if such vehicle tracking BMPs are not adequate to prevent sediment from being tracked onto the street.
- The Permittee(s) must install temporary sedimentation basins as required in accordance with permit requirements.
- Minimize soil compaction by restricting vehicle access in areas where final vegetative stabilization will occur, unless otherwise infeasible.
- Discharges from BMPs shall be directed to vegetated areas unless infeasible.
- Preserve a 50 foot natural buffer or (if a buffer is infeasible on the site) provide redundant (double) perimeter sediment controls when a surface water is located within 50 feet of the project's earth disturbances and stormwater flows to the surface water.
- Perimeter sediment controls shall be installed at least 5 feet apart unless limited by lack of available space. Natural buffers are not required adjacent to road ditches, judicial ditches, county ditches, stormwater conveyance channels, storm drain inlets, and sediment basins. If preserving the buffer is infeasible, the reasons for which shall be recorded in the SWPPP.
- The use of polymers, flocculants, or other sedimentation treatment chemicals, if used on the project, shall be used in accordance with accepted engineering practices, dosing specifications, and sediment removal design specifications provided by the product manufacturer or supplier. Use conventional erosion and sediment controls prior to the chemical addition to ensure effective treatment. Chemicals may only be applied where treated stormwater is directed to a sediment control system which allows or filtration of settlement of the floc prior to discharge.
- If the proposed project as shown on the plans has 10 or more acres draining to a common location or 5 acres or more if the site is within one mile of a special or impaired water (as identified in Section II - Receiving Waters and Environmentally Sensitive Areas), then a temporary sediment basin must be constructed as shown on the plans. Temporary sediment basins will have a minimum of 3,600 cubic feet of storage per acre draining to the basin. The basin outlet shall provide for discharging water from the surface to minimize discharging of pollutants. A stabilized emergency overflow shall be constructed.

DEWATERING AND BASIN DRAINING (SECTION 10)

- Discharge turbid or sediment-laden waters related to dewatering or basin draining (e.g., pumped discharges, trench/ditch cuts for drainage) to a temporary or permanent sediment basin on the project site unless infeasible. Discharge from the temporary or permanent sedimentation basins to surface waters if the basin water has been visually checked to ensure adequate treatment has been obtained in the basin and that nuisance conditions will not result from the discharge. If the water cannot be discharged to a sedimentation basin prior to entering the surface water, it must be treated with the appropriate BMPs, such that the discharge does not adversely affect the receiving water or downstream properties.
- Discharge water that contains oil or grease, must use an oil-water separator or suitable filtration device (e.g. cartridge filters, absorbents pads) prior to discharging the water.
- All water from dewatering or basin-draining activities must be discharged in a manner that does not cause nuisance conditions, erosion in receiving channels or downslope properties, erosion or scour in the immediate vicinity of discharge points, or inundation in wetlands causing significant adverse impact to the wetland.
- The use of filters with backwash water, haul the backwash water away for disposal, return the backwash water to the beginning of the treatment process, or incorporate the backwash water into the site in a manner that does not cause erosion. Discharge backwash water to the sanitary sewer if permission is granted by the sanitary sewer authority. Replace and clean the filter media used in dewatering devices when required to retain adequate function.

INSPECTIONS AND MAINTENANCE (SECTION 11)

- Owner and Contractor shall ensure that a trained person (as identified in item 21.2.b) of the permit will inspect the entire construction site at a minimum:
 - Once every seven (7) days during active construction, and
 - Within 24 hours after a rainfall event greater than 1/2 inch in 24 hours
- Inspect all erosion prevention and sediment control BMPs and Pollution Prevention Management Measures to ensure integrity and effectiveness during all routine and post-rainfall event inspections. All nonfunctional BMPs must be repaired, replaced, or supplemented with functional BMPs by the end of the next business day after discovery, or as soon as field conditions allow access unless another time frame is specified below. Investigate and comply with the following Inspection and Maintenance requirements:
 - All perimeter control devices must be repaired, replaced, or supplemented when they become nonfunctional or the sediment reaches one-half (1/2) of the height of the device. These repairs must be made by the end of the next business day after discovery, or thereafter as soon as field conditions allow access.
 - Temporary and permanent sedimentation basins must be drained and the sediment removed when the depth of sediment collected in the basin reaches one-half (1/2) the storage volume. Drainage and removal must be completed within 72 hours of discovery, or as soon as field conditions allow access.
 - Surface waters, including drainage ditches and conveyance systems, must be inspected for evidence of erosion and sediment deposition during each inspection. Remove all deltas and sediment deposited in surface waters, including drainage ways, catch basins, and other drainage systems, and restabilize the areas where sediment removal results in exposed soil. The removal and stabilization must take place within seven (7) days of discovery unless precluded by legal, regulatory, or physical access constraints. Use all reasonable efforts to obtain access. If precluded, removal and stabilization must take place within seven (7) calendar days of obtaining access. Contact all local, regional, state and federal authorities and receiving any applicable permits, prior to conducting any work in surface waters.
 - Construction site vehicle exit locations must be inspected for evidence of off-site sediment tracking onto paved surfaces. Tracked sediment must be removed from all paved surfaces both on and off site within 24 hours of discovery, or if applicable, within a shorter time.
 - Streets and other areas adjacent to the project must be inspected for evidence of off-site accumulations of sediment. If sediment is present, it must be removed in a manner and at a frequency sufficient to minimize off-site impacts (e.g., fugitive sediment in streets could be washed into storm sewers by the next rain and/or pose a safely hazard to users of public streets).
- Inspection frequency adjustment:
 - Inspections of areas with permanent cover can be reduced to once per month, even if construction activity continues on other portions of the site, or
 - where sites have permanent cover on all exposed soil and no construction activity is occurring anywhere on the site, inspections can be reduced to once per month and, after 12 months, may be suspended completely until construction activity resumes. The MPCA may require inspections to resume if conditions warrant, or
 - where construction activity has been suspended due to frozen ground conditions, inspections may be suspended. Inspections must resume within 24 hours of runoff occurring, or upon resuming construction, whichever comes first.
- All inspections and maintenance activities within 24 hours of being conducted must be recorded and retained in the SWPPP. These records must include:
 - Date and time of inspections
 - Name of person(s) conducting inspections
 - Findings of inspections, including the specific location where corrective actions are needed
 - Corrective actions taken (including dates, times, and party completing maintenance activities)
 - Date and amount of all rainfall events greater than 1/2 inch (0.5 inches) in 24 hours. Rainfall amounts must be obtained by a properly maintained rain gauge installed onsite, a weather station that is within 1 mile of your location or a weather reporting system that provides site specific rainfall data from radar summaries.
 - If any discharge is observed to be occurring during the inspection, a record of all points of the property from which there is a discharge must be made, and the discharge should be described (i.e., color, odor, floating, settled, or suspended solids, foam, oil sheen, and other obvious indicators of pollutants) and photographed.
 - Any amendments to the SWPPP proposed as a result of the inspection must be documented within seven (7) calendar days.
- All infiltration areas must be inspected to ensure that no sediment from ongoing construction activity is reaching the infiltration area. All infiltration areas must be inspected to ensure that equipment is not being driven across the infiltration area.

POLLUTION PREVENTION MANAGEMENT MEASURES (SECTION 12)

Implement the following pollution prevention management measures on the site:

- Storage, Handling, and Disposal of Construction Products, Materials, and Wastes shall comply with the following to minimize the exposure to stormwater of any of the products, materials, or wastes. Products or wastes which are either not a source of contamination to stormwater or are designed to be exposed to stormwater are not held to this requirement:
 - Building products that have the potential to leach pollutants must be under cover (e.g., plastic sheeting or temporary roofs) to prevent the discharge of pollutants or protected by a similarly effective means designed to minimize contact with stormwater.
 - Pesticides, herbicides, insecticides, fertilizers, treatment chemicals, and landscape materials must be under cover (e.g., plastic sheeting or temporary roofs) to prevent the discharge of pollutants or protected by similarly effective means designed to minimize contact with stormwater.
 - Hazardous materials, toxic waste, (including oil, diesel fuel, gasoline, hydraulic fluids, paint solvents, petroleum-based products, wood preservatives, additives, curing compounds, and acids) must be properly stored in sealed containers to prevent spills, leaks or other discharge. Restricted access storage areas must be provided to prevent vandalism. Storage and disposal of hazardous waste or hazardous materials must be in compliance with Minn. R. ch. 7045 including secondary containment as applicable.
 - Solid waste must be stored, collected and disposed of properly in compliance with Minn. R. ch. 7035.
 - Portable toilets must be positioned so that they are secure and will not be tipped or knocked over. Sanitary waste must be disposed of properly in accordance with Minn. R. ch. 7041.
- Fueling and Maintenance of Equipment or Vehicles. Spill Prevention and Response: Take reasonable steps to prevent the discharge of spilled or leaked chemicals, including fuel, from any area where chemicals or fuel will be loaded or unloaded including the use of drip pans or absorbents unless infeasible. Conduct fueling in a contained area unless infeasible. Ensure adequate supplies are available at all times to clean up discharged materials and that an appropriate disposal method is available for recovered spilled materials. Report and clean up spills immediately as required by Minn. Stat. § 115.061, using dry clean up measures where possible.
- Vehicle and equipment washing: Wash the exterior of vehicles or equipment on the project site, washing must be limited to a defined area of the site. Runoff from the washing area must be contained in a sediment basin or other similarly effective controls and waste from the washing activity must be properly disposed of. Properly use and store soaps, detergents, or solvents. No engine degreasing is allowed on site.
- Concrete and other washouts waste: Provide effective containment for all liquid and solid wastes generated by washout operations (concrete, stucco, paint, form release oils, curing compounds and other construction materials) related to the construction activity. The liquid and solid washout wastes must not contact the ground, and the containment must be designed so that it does not result in runoff from the washout operations or areas. Liquid and solid wastes must be disposed of properly and in compliance with MPCA rules. A sign must be installed adjacent to each washout facility that requires site personnel to utilize the proper facilities for disposal of concrete and other washout wastes.

PERMIT TERMINATION (SECTIONS 4 AND 13)

- Permittees must submit a NOT within 30 days after all termination conditions listed in Section 13 are complete.
 - Permittees must submit a NOT within 30 days after selling or otherwise legally transferring the entire site, including permit responsibility for roads (e.g., street sweeping) and stormwater infrastructure final clean out, or transferring portions of a site to another party. The permittees' coverage under the permit terminates at midnight on the submission date of the NOT.
 - Permittees may terminate permit coverage prior to completion of all construction activity if they meet all of the following conditions:
 - Construction activity has ceased for at least 90 days; and
 - at least 90 percent (by area) of all originally proposed construction activity has been completed and permanent cover has been established on those areas; and
 - on areas where construction activity is not complete, permanent cover has been established; and
 - the site complies with items 13.3 through 13.7 of the permit.
- After permit coverage is terminated under this item, any subsequent development on the remaining portions of the site will require permit coverage if the subsequent development itself or as part of the remaining common plan of development or sale will result in land disturbing activity of one (1) or more acres in size.
- Permittees may terminate coverage upon MPCA approval after submitting information documenting the owner canceled the project.
 - Permittees must complete all construction activity and must install permanent cover over all areas prior to submitting the NOT. Vegetative cover must consist of a uniform perennial vegetation with a density of 70 percent of its expected final growth. Vegetation is not required where the function of a specific area dictates no vegetation, such as impervious surfaces or the base of a sand filter.
 - Permittees must clean the permanent stormwater system of any accumulated sediment and must ensure the system meets all applicable requirements in Section 15 through 19 of the permit and is operating as designed.
 - Permittees must remove all sediment from conveyance systems prior to submitting the NOT.
 - Permittees must remove all temporary synthetic erosion prevention and sediment control BMPs prior to submitting the NOT. BMPs designed to decompose on-site may be left in place.
 - For residential construction only, permit coverage terminates on individual lots if the structures are finished and temporary erosion prevention and downgradient perimeter control is complete, the residence sells to the homeowner, and the permittee distributes the MPCA's "Homeowner Fact Sheet" to the homeowner.
 - For construction projects on agricultural land (e.g., pipelines across cropland), disturbed land must be returned to its preconstruction agricultural condition prior to submitting the NOT.
 - When submitting the NOT, permittees must include either ground or aerial photographs showing vegetative cover requirements have been met as listed above. All submitted photographs shall include the date and specific site location.

LONG TERM OPERATION AND MAINTENANCE:

- Upon the completion of construction activity and NPDES permit termination, in accordance with Sections 4 and 13, the Property Owner shall become the responsible party for long term operation and maintenance (O&M) of all permanent stormwater management features under this project.
- All associated operations, inspections, maintenance, and record keeping shall be performed by trained individual(s) familiar with the site stormwater management system.
- Record keeping of inspections and maintenance items shall be maintained by the Owner in accordance with applicable Maintenance Agreements/Declarations as required by local jurisdictional authorities.



© 2023 Larson Engineering, Inc. All rights reserved.

TWIN TOWN
DEMOLITION
13385 207TH AVENUE NW
ELK RIVER, MN 56330

Client:

TWIN TOWN DEMOLITION
NEW BUILDING
LOT 5, BLOCK 3, CREEKSIDE FARMS
HAM LAKE, MN

Project Title:

I hereby certify that this plan, specifications or report was prepared by me or under my direct supervision and that I am a duly licensed Professional Engineer under the laws of the state of Minnesota.

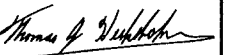
Thomas J. Herkenhoff, P.E.

Date: 12.01.23 Lic. No.: 25520

Rev	Date	Description
△	11.28.23	CITY COMMENTS
△	11.29.23	CITY COMMENTS

Project #: 12236155
Drawn By: KBK
Checked By: TJH
Issue Date: 12.01.23

Sheet Title:

SWPPP

Sheet:

C501

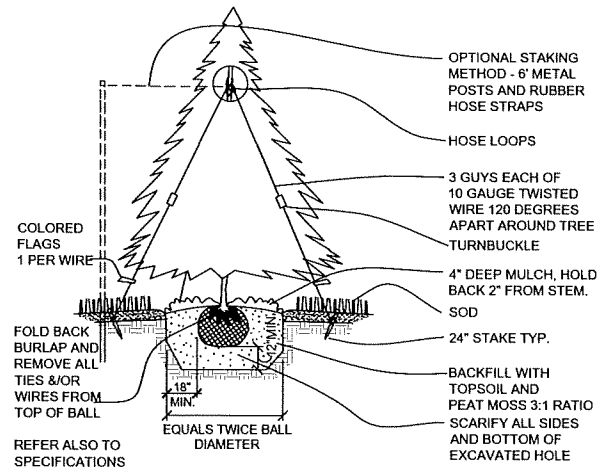

CONIFEROUS TREE PLANTING DETAIL

1
C600

NOT TO SCALE

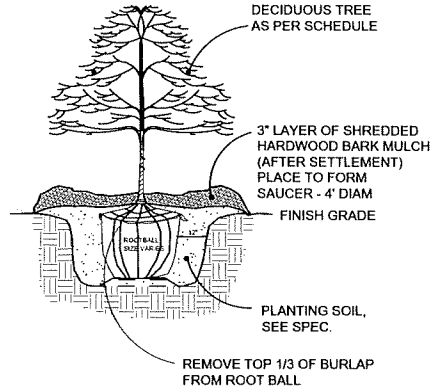

DECIDUOUS TREE PLANTING DETAIL

2
C600

NOT TO SCALE

NOTES:

PROVIDE AND INSTALL PLANT MATERIALS THAT MEET SPECIFICATIONS AND ARE OF THE SIZE, TYPE, AND SPECIES GIVEN IN PLANT SCHEDULE.

REMOVE DEAD OR DAMAGED BRANCHES. RETAIN THE NATURAL FORM OF THE TREE OR SHRUB.

DO NOT CUT THE LEADER.

PLACE WEED BARRIER. DIG PLANT HOLES 12" MIN. LARGER THAN BALL, ALL SIDES. BACK FILL WITH PLANTING SOIL - SEE SPEC. SCARIFY BOTTOM OF PLANTING HOLE. REFER TO SPECIFICATIONS FOR ADDITIONAL INFORMATION.

IN CASE OF ANY DISCREPANCIES BETWEEN THIS DETAIL, PLANS OF SPECIFICATIONS, THE SPECIFICATION SHALL GOVERN.

SYMBOL LEGEND

RESTORE ALL DISTURBED AREAS WITH 4" OF TOPSOIL AND TURF SEED

PLANTING SCHEDULE

	QTY	COMMON NAME	BOTANICAL NAME	SIZE	CONTAINER
	5	Sienna Glen Maple	Acer X Freemanii 'Sienna'	2-1/2" Cal	B & B
	2	Common Hackberry	Celtis Occidentalis	2-1/2" Cal	B & B
	28	Black Hills Spruce	Picea Glauca 'Densata'	6'	B & B
	15	Norway Spruce	Picea Abies	6'	B & B

NOTES

- UNLESS OTHERWISE NOTED, ALL AREAS SHALL BE RESTORED WITH 4" OF TOPSOIL AND SEED.
- ALL SLOPES THAT ARE IN EXCESS OF 3:1 (H:V) SHALL BE SECURED WITH NORTH AMERICAN GREEN DS150 FOR SHORT TERM EROSION CONTROL (CATEGORY 3).
- ACTUAL TREE SIZE MAY BE SMALLER THAN THAT SHOWN BUT SHALL BE IN ACCORDANCE WITH CITY OF HAM LAKE LANDSCAPE REQUIREMENTS AND TIMELINES.

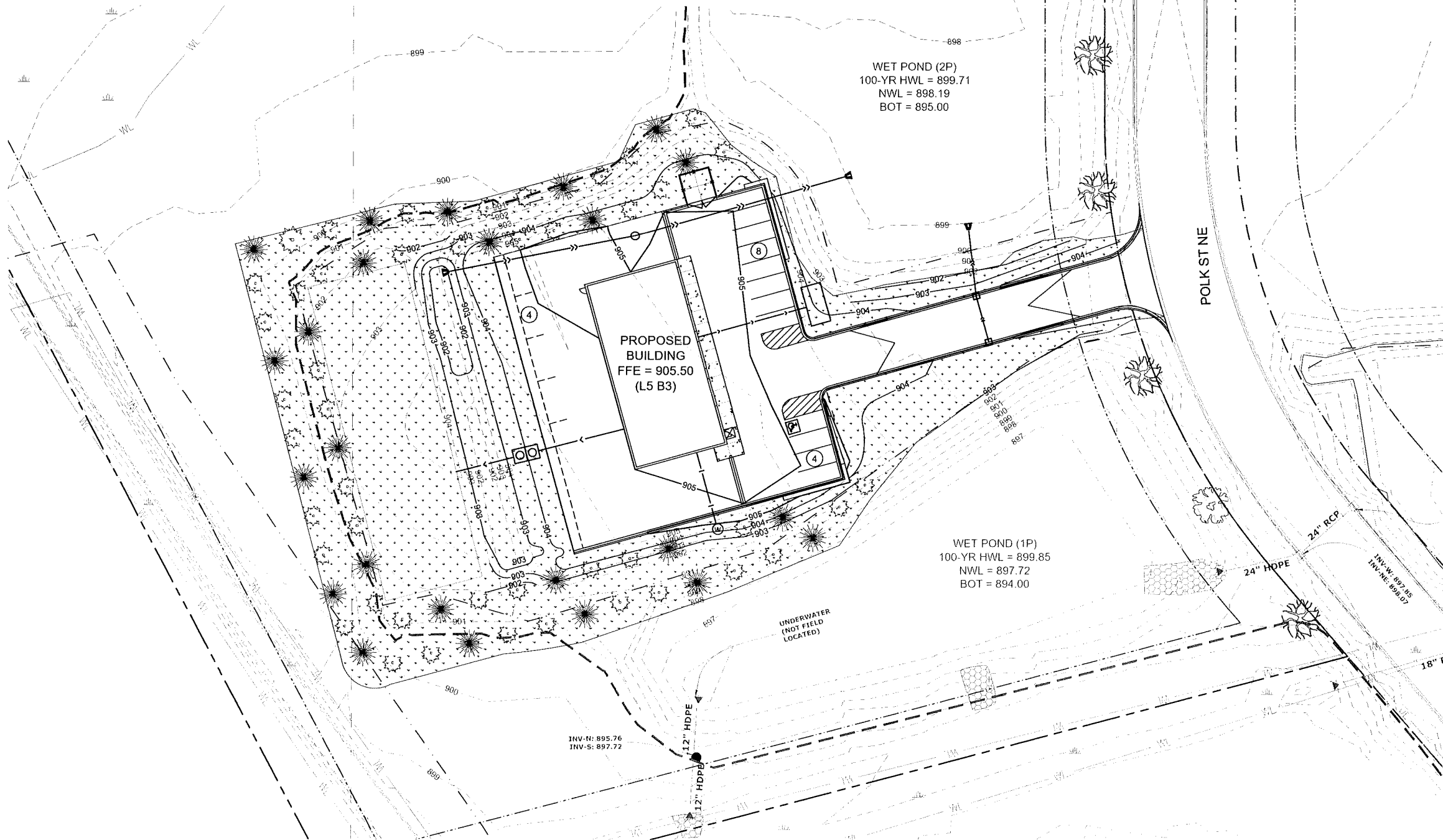

NORTH

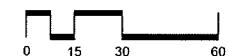

Larson Engineering, Inc.
816 W. St. Germain Street
Suite 308 St. Cloud, MN 56301
320.428.5624
www.larsonengr.com

TWIN TOWN DEMOLITION
NEW BUILDING
13385 207TH AVENUE NW
ELK RIVER, MN 56330

TWIN TOWN DEMOLITION
NEW BUILDING
LOT 5, BLOCK 3, CREEKSIDE FARMS
HAM LAKE, MN

I hereby certify that this plan, specifications or report was prepared by me or under my direct supervision and that I am a duly licensed Professional Engineer under the laws of the state of Minnesota.

Thomas J. Herkenhoff
Thomas J. Herkenhoff, P.E.
Date: 12.01.23 Lic. No.: 25520

Rev	Date	Description
△	11 28 23	CITY COMMENTS
△	11 29 23	CITY COMMENTS

Project #: 12236155
Drawn By: KBK
Checked By: TJH
Issue Date: 12.01.23
Sheet Title:

LANDSCAPING PLAN

Sheet:
C600

Excerpt from Article 9 of the Ham Lake City Code

...

9-220 Mercantile Districts The land uses described in Article 9-220 are intended to be applicable to developments which utilize subsurface sewage treatment systems (SSTS), and to developments which use approved combined sewage treatment systems. All building permits and Certificates of Occupancy in the Mercantile Districts shall require the review and approval of the City Council, after review and recommendation by the Planning Commission, excepting building permits and/or certificates of occupancy being issued for an alteration to an existing structure under circumstances in which the land use will be unchanged, and in which the alteration will not materially affect parking requirements, stormwater runoff, traffic, sewage treatment needs or aesthetics.

9-220.1 Standards Common to All Mercantile Districts

The following standards shall apply to all of the mercantile districts as listed in Article 9-220.

- a) **Paving** All parking lots, drives and surfaces upon which the general public and employees shall have access shall be paved according to specifications to be established by the city's engineer;
- b) **Drainage** Surface water drainage and ponding needs shall be implemented in the manner directed by the city's engineer;
- c) **Landscaping** Landscaping shall be implemented in the manner provided in Article 11-1800;
- d) **Setbacks for Paved Areas** There shall be a ten-foot setback between any lot line and the back of curb of any parking lot or driveway, and a six-foot setback between the back of curb of any parking lot and any building;
- e) **Buffering** When any mercantile land use is located adjacent to a residential area, it shall be screened by opaque fencing, vegetation, or both;
- f) **Refuse Containers** Refuse containers shall be stored in locations which are completely screened from outside view; hazardous materials shall be stored and disposed of in the manner provided by law;
- g) **Parking Lots and Lighting** Off-street parking shall be provided for the general public and employees. The *Zoning Officer* shall maintain a schedule of parking requirements, to be ratified from time to time by resolution of the City Council, to serve as the general guideline for the establishment of parking requirements, subject to modification by the City Council where merited. Security lighting shall be permitted, and may be required on review of site plans, but shall be directed away from adjacent properties. No light or

combination of lights that cast light upon a Residential Land Use shall exceed 4-foot candle meter reading as measured at the residential property line. All measurements shall be made after dark at the property line or edge of roadway.

- h) Off-Street Loading** All deliveries and bulk pickups of merchandise, inventory and supplies shall be made to loading facilities preferably located in the rear of the building, which loading facilities shall be sufficient to enable the prompt and safe transfer of goods.
- i) Signage** All signage shall conform to the provisions of Article 11-300.
- j) Special Considerations** Notwithstanding the limitations as to building styles, construction types and exterior treatments, the City Council, after Planning Commission review, may depart from strict adherence to the standards found in Article 9-220, where special conditions merit such departure, and where certain standards are met. Such special conditions and standards may include, without limitation, the following items.

 - i)** The departure is not being requested for purely economic reasons;
 - ii)** The nature of the business is such that it requires a specific type of building construction in order to improve the business function, such as requirements for sunlight, specialty equipment, interior lighting or the like;
 - iii)** The business is a permitted or conditional use in the zoning district;
 - iv)** The applicant proposes the usage of special aesthetic treatments which provide a superior exterior view, such as landscaping, vegetation screening, berming, or the like;
 - v)** The property contains unusual topography, mature vegetation or other features which can be preserved or enhanced to produce an overall superior appearance;
 - vi)** The property contains unusual accessibility problems to or from adjacent roadways;
 - vii)** The applicant offers to implement more stringent design limitations in certain site plan features than would normally be required, in exchange for being

permitted less stringent design limitations in other site plan features.

- k) **Outside Storage** Outside storage and activities for areas zoned CD-3, CD-4, Industrial Park (I-P) and Light Industrial (I-1) shall be as specifically detailed in the Code Sections dealing with those land uses (Articles 9-220.4 through 9-220.7). For areas zoned CD-1 and CD-2, the following provisions shall apply to outside storage, excepting Fireworks sales and storage, which are governed by the provisions of Article 9-330.6. **Unless specifically permitted by this Article 220.1(k), no Outside Storage shall be allowed in any area zoned CD-1 or CD-2.**

1) Definitions

- aa) **Outside Storage** – personal property (not fixtures) that are located within the Approved Property Lines of any parcel bearing a CD zoning classification, but which are found outside of an enclosed, roofed building (including temporary structures). Outside Storage does not include Refuse Containers, customer vehicles, employee vehicles parked while the employee is on duty, delivery vehicles while in the process of delivery or pickup, construction materials or vehicles being used in an active construction project on the parcel, legal signs or banners, or legal temporary structures. Except where specifically excepted, Outside Storage does include inventory of the business occupying the parcel.
- bb) **Inventory** - goods, except Vehicle Inventory, that are offered for sale in the ordinary course of business of any business occupying the parcel. For auto repair shops, inventory shall also be deemed to mean passenger vehicles or pickup trucks awaiting repair services.
- cc) **Vehicle Inventory** – Automobiles, Trucks, Trailers, Manufactured Homes, Recreational Vehicles, Campers, Camper Tops, Truck Toppers, Boats or other wheeled conveyances that are offered for retail sale at a legal business location whose primary business is the retail sale of one or more of the above items. Rental equipment that may be offered for sale is not Vehicle Inventory. Vehicle Inventory that bears obvious signs that the vehicle is not presently capable of being legally operated or conveyed on a public road is not Vehicle Inventory, including, but not limited to vehicles lacking wheels or inflated tires, operable drive train components, broken windows or lights, required current vehicle registration, missing body parts, such as fenders, doors, hood lids, trunk lids, bumpers, lights or trim.

- dd) **Aesthetically Screened Outside Storage** - Inventory or Vehicle Inventory behind an opaque barrier constructed of masonry or brick, attached to and matching or complementary to the main building, and of sufficient height and design so as to give the appearance that the barrier is a part of the main building. No object shall be stored inside of such a barrier if the object protrudes above the height of the barrier. Any gates through the barrier shall be opaque and of aesthetic design.
- ee) **Limited Outdoor Displays** - Temporary displays of merchandise which are normally sold or displayed from within an enclosed retail store location, but which are temporarily placed not more than ten feet from an outside wall of the main retail sales building during business hours, and then returned to inside storage during non-business hours.”
- ff) **Improvement Stores** – Businesses that have as their primary source of revenue the retail sale of plants, seeds, landscaping supplies, produce, or yard statuary.
- gg) **24-Hour Convenience Stores** – Businesses that sell gasoline at retail, and, from the same store location, also sell groceries, auto supplies, sundries, over-the-counter medications and personal products, sundries and other items for human consumption, and which remain open for business at all times of every day.
- hh) **Approved Property Lines** – Are the outside perimeter of the real estate parcel or parcels which were shown on the site plan used for the initial municipal approval of a certificate of occupancy or conditional use permit for a particular operation.
- ii) **Pool Stores** – retail stores that engage in the retail sales of above ground or below ground recreational swimming pools that contain electric filtration devices providing water circulation and filtration in the pool, and under conditions where an inventory of above ground or in ground swimming pools is maintained, connected by water and electricity to a source originating in a permanent retail building located on the same parcel. A Pool Store shall not be considered a retail store for the purposes of determining permitted uses under Article 9-220.2 (b) or 9-220.3(b).
- jj) **Screened Outside Storage** – is Inventory or Vehicle Inventory behind an opaque barrier constructed of wood, metal, plastic, masonry, brick or earthen berm, or which is behind an opaque barrier composed of existing buildings or other structures on the property, or which is behind a semi-opaque barrier of vegetation that substantially conceals the storage from outside view.

2) Permitted Outside Storage

- aa) Vehicle Inventory is permitted Outside Storage on any CD-1 or CD-2 parcel in connection with a business that is legally permitted to sell Vehicle Inventory. If specifically permitted by the conditions of any Conditional Use Permit or Temporary Conditional Use Permit for any such parcel, vehicles that do not meet the definition of Vehicle Inventory may also be permitted Outside Storage.
- bb) **Aesthetically Screened Outside Storage** is permitted outside storage if used as a condition of approval of any site plan, Conditional Use Permit or Temporary Conditional Use Permit on any CD-1 or CD-2 parcel in connection with the new construction of a main commercial building on the parcel.
- cc) Limited Outdoor Displays are permitted Outside Storage in both the CD-1 and CD-2 districts. If the business is a 24-Hour Convenience Store, the Limited Outdoor Display need not be moved indoors, but the business shall at all times maintain a clear pedestrian path on sidewalks that is at least 36 inches in width.
- dd) Inventory is permitted Outside Storage for Improvement Stores and Manufactured/Prefabricated Structure Sales but must be separately identified on the initial site plan submitted with the initial request for certificate of occupancy or conditional use permit, and must be stored only in conformance with that site plan. Bins or containers housing the Inventory shall also be permitted Outside Storage for Improvement Stores and Manufactured/Prefabricated Structure Sales as shall be other items necessarily incident to the storage, maintenance or protection of the Inventory.
- ee) No Outside Storage shall be permitted for any business unless the storage is within the Approved Property Lines.
- ff) Pool Stores may display above ground or below ground swimming pools as Permitted Outside Storage only on property under conditional use permit, subject to conditions to be established by the City Council, which must include, at a minimum, the following:
 - 1) Pool water must be maintained in a sanitary condition;
 - 2) Below ground pools must be surrounded by code-compliant fencing;
 - 3) Above ground pools must be constructed in a code-compliant method relative to either fencing or sufficient elevation to prevent accidental entry into the pool;
 - 4) Adequate security fencing around the storage display area must be installed to discourage after-hours entry into the pool storage area;

- 5) Reasonable screening from outside view shall be installed;
- 6) All sources of water and electricity shall be connected to the pools in a code-compliant manner;
- 7) Only pools that are intended for use with circulating filters shall be permitted outside; no “kiddy pools”, wading pools or inflatable pools shall be permitted to be displayed outside.
- 8) Winter storage of outside pools shall be done in a manner that covers the pool surface and prevents the accidental entry into the pool;

gg) Screened Outside Storage is permitted outside storage if used as a condition of approval of any site plan, Conditional Use Permit or Temporary Conditional Use Permit on any CD-1 or CD-2 parcel involving pre-existing main buildings or structures that:

- 1) Historically utilized outside storage in connection with business operating on the property, and which uses were never abandoned;
- 2) Do not involve replacement or major remodeling of the existing structures, but utilizes the existing structures for the business to be operated;

Approval of Screened Outside Storage is discretionary with the City Council.

hh) Revocation All permits and certificates of occupancy issued in the mercantile districts are subject to revocation under the provisions of Article 9-240.

3) Office/Warehouses Office/Warehouse is a term given to a structure that is designed to have office space in front, behind which is situated an open bay or bays, with the office and bay space to be occupied by a single business. The office space and the bay space may also include area for retail sales. The bay space may also be used for manufacturing, other industrial activity, or warehousing. Building Permits may be issued for Office/Warehouses in any Mercantile District as found in Article 9-220. However, specific uses within each Office/Warehouse are subject to the Permitted Use, Conditional Use and Temporary Conditional Use restrictions for the given zoning district in which the Office/Warehouse is constructed. The issuance of a building permit for an Office/Warehouse does not confer upon the property owner the right to use any portion of the structure in a manner inconsistent with the use restrictions for the zoning district in which the structure is located. All new tenants or occupants of any Office/Warehouse must observe the same conditions for site plan or other approval, as would any other occupant. Further, if the zoning district in which the Office/Warehouse is to

be constructed contains restrictions on building materials or design, those restrictions must be followed. No outside storage unless permitted by Conditional Use Permit, Temporary Conditional Use Permit, or by the given zoning district in which the Office/Warehouse is constructed.

9-220.2 Commercial Development I (CD-1)

The CD-1 zone is intended to apply to certain commercial uses on lands abutting the city's only major thoroughfare, Trunk Highway 65. In that these lands have high visibility to the traveling public, it is considered important to the preservation of land values in general, as well as important to the continuing ability of the city to generate the establishment of quality commercial development and the concomitant tax and employment base, that structures in the CD-1 zones observe specific construction and aesthetic standards, which are listed below. No usage shall be permitted in the CD-1 zone which does not observe the standards found in Article 9-220.2 (a) below.

...

9-220.3 Commercial Development II (CD-2)

The CD-2 Districts are located adjacent to the CD-1 Districts, and constitute a second tier of commercial activities along the T.H. 65 corridor. These districts also have importance in presenting a visually pleasing image to the traveling public, but are less visible from the T.H. 65 roadway than the CD-1 districts.

a) Standards for Site and Building Construction

- i) Metal or pole-type buildings shall be permitted if surfaces meet the requirements of ii below, and, provided that no galvanized surface may appear, all roofs shall be colored and incorporate a minimum 18-inch soffit on eave edges, 12-inch overhang on gable ends, and 6-inch fascia.
- ii) Metal panel with exposed fasteners or architectural metal panel with hidden fasteners may be used for roof surfaces. All wall surfaces may be composed of metal panel, brick, decorative masonry, stone, precast panel, architectural concrete, glass, stucco or wood framed with horizontal lap siding. The exterior wall surface facing or with the most exposure to a public street or right-of-way, shall have a wainscot at least 42-inches in height which is composed of a contrasting color or material.

b) Permitted Uses (Including uses that are ancillary to the main use)

- All Permitted Uses in the CD-1 District
- Broadcasting Studios
- Building Supply Yards/Lumber Yards
- Enclosed Storage and Office/Warehousing
- Landscaping Businesses
- Manufacturing involving no non-enclosed storage
- Public Utilities (metal or pole type construction allowed)
- Research laboratories
- Used Vehicle Sales - limited to the following:
 - ATV's (all-terrain vehicles)
 - Automobiles
 - Boats
 - Campers
 - Golf Carts
 - Motorcycles, Motorbikes and Scooters
 - Recreational Vehicles
 - Snowmobiles
 - Commercial Trucks
 - Pickup Trucks
 - Trailers less than 30 feet in length
- Utility Companies

c) Conditional Uses

- All conditional uses or temporary conditional uses in the CD-1 District
- Construction Service Contractors such as Concrete Masonry, Roofing, Siding, and Landscaping Contractors
- Flea Markets under Article 11-1500
- Kennels
- Pawn Shops under Article 11-1300
- Truck Terminals – as defined as a location where commercial trucks load and unload cargo on a regular basis with Large Truck and Equipment Repair (Body and Driveline Repair) as a secondary use
- Self-storage facilities, but not including the limitations and conditions imposed for such facilities as found in Article 9-220.2 (c).

Excerpt from Article 11 of the Ham Lake City Code

...

11-1800 LANDSCAPING IN COMMERCIAL ZONED AREAS

In all areas of the City zoned CD-1, CD-2, CD-3 or CD-4, the following conditions shall apply to landscaping and ground cover.

11-1810 Landscape Plan Required No building permit shall be issued for construction on a vacant lot, nor for any addition to an existing building involving the addition of 500 square feet or more of additional building space, unless the applicant shall have first submitted and obtained approval of the City Council, after review by the Planning Commission, of a landscaping plan meeting the requirements of this code.

11-1820 Installation Required No certificate of occupancy shall be issued for any construction which required a landscaping plan unless the applicant has installed all of the elements of the landscaping plan, or unless the applicant has posted security acceptable to the City to guarantee timely installation of all landscaping.

11-1830 Time for Submission The landscaping plan shall be submitted, whenever possible, at the time of site plan approval. If the landscaping plan is not submitted at the time of site plan approval, it must be separately reviewed by the Planning Commission and approved by the City Council prior to the issuance of any building permits.

11-1840 Contents and Specifications

The landscaping plan shall be a quality document prepared at a scale of one-inch equals thirty feet, showing all relevant dimensions. Fifteen copies of the plan shall be submitted by the applicant. The following data shall be displayed on the plan, legibly labeled:

- A. Perimeter of all buildings, signs or other structures;
- B. Parking lots and walkways, identifying pavement material;
- C. Areas of decorative rock, identifying type of rock;
- D. Areas of lawn;
- E. Other areas where other than natural wooded vegetation is to be used as ground cover, identifying the ground cover to be used;
- F. Locations, trunk size, height and species of all trees to be planted;
- G. Locations where existing natural wooded vegetation will remain undisturbed;
- H. All other landscaping features to be used.

11-1850 MINIMUM LANDSCAPING REQUIREMENTS

11-1851 Paved Surfaces All surfaces upon which motor vehicles will be parked or driven, and all areas in which pedestrians will be walking from point to point shall be surfaced with asphalt or concrete, to specifications established by the City's engineer.

11-1852 Ground Cover On any side of a lot which abuts a public road, the area from the road right-of-way to the nearest building side shall be entirely covered with ground cover consisting of pavement, decorative rock bordered with edging, lawn grass intended for regular mowing, mulch, bark, wood chips or other commonly used landscaping ground cover. Shingles, aggregate and clay mixtures such as Class V material, recycled concrete or asphalt, and other non-conventional ground covers shall not be permitted. Loose ground cover shall be installed to a depth of at least three inches. Any area which is covered by landscaping ground cover (not lawn or pavement) shall also include one decorative shrub for each ten square feet of ground cover.

Side yards and rear yards which do not contain existing natural wooded vegetation shall either be covered with ground cover in the manner stated above for front yards, or shall be planted so as to encourage the emergence of natural wooded vegetation, through the planting of tree species expected to reach a height of at least twenty five feet. Areas so prepared shall not be required to have mown lawn areas, but may be allowed to return to a natural state.

11-1853 Tree Plantings Trees which are planted outside of areas intended to return to a natural wooded state shall be of a variety indigenous to the local climate. Deciduous trees shall, when planted, have a trunk size of at least one and one half inches at a height of four feet from ground level. Conifers shall have a height of at least five feet. Tree locations are subject to review and approval of the City in the landscaping plan review process, and while no specific number of trees are required, the following general principles shall be observed;

- A. Where property lines are adjacent to residential areas, a planting screen of conifers shall be required, of sufficient size and proximity to provide an intermingled screen within five years;
- B. Decorative trees shall be planted along the right of way lines of adjacent public roadways;
- B. The use of conifers shall be encouraged and preferred.
- C. Whenever possible, an attempt will be made to preserve stands of existing vegetation, particularly treed or wooded areas.

11-1860 Case by Case Evaluation

Recognizing that the City contains a wide variety of commercial land, the landscape approval process shall be on a case by case basis. Where wetlands are present, or where large distances separate a commercial lot from adjacent lands, for example, strict adherence to screening requirements may be unnecessary. Likewise, strict adherence to the remaining provisions of Article 11-1800 may be unnecessary where size, spatial relationships, topography or other physical features render a given landscaping plan aesthetically acceptable, and departures from the strict observance of the elements of Article 11-1800 shall not be considered variances requiring a showing of physical hardship. Conversely, an applicant shall be expected to meet the general spirit of this article in establishing an aesthetically pleasing landscaping plan.

NOTICE OF PERMIT APPLICATION STATUS

Project: Twin Town Demolition

Date: December 1, 2023

Applicant: Twin Town Demolition
Attn: Nick Holm
13385 207th Ave NW
Elk River, MN 55330

Permit Application#: P-23-071

Purpose: construction of a new commercial building and parking lot

Location: NW of the intersection of Buchanan St NE and 166th Ave NE, 16648 Polk St NE
, Ham Lake

At their meeting on 11/13/2023 the Board of Managers of the Coon Creek Watershed District **Approved with Conditions** the above referenced project with 3 conditions and 0 stipulations. **This is NOT a permit.**

Since the last submittal on 11/29/2023, the following conditions remain which must be addressed before permit issuance.

1. Update the erosion and sediment control plan to include a note to stabilize soils and soil stockpiles within 24 hours of inactivity.

Please be advised that **this is NOT a permit**, and that work without a permit is a violation of the terms of the Coon Creek Watershed District Rules. If you have any questions, please call 763-755-0975.

Sincerely,



Erin Edison
Watershed Development Coordinator

cc: File P-23-071
Eileen Weigel, Stantec
Danielle Tourtillott, Stantec
Tom Collins, Ham Lake