



CITY OF HAM LAKE

15544 Central Avenue NE
Ham Lake, Minnesota 55304
(763) 434-9555
Fax (763) 434-9599

CITY OF HAM LAKE PLANNING COMMISSION AGENDA MONDAY, AUGUST 14, 2023

CALL TO ORDER: 6:00 p.m.

PLEDGE OF ALLEGIANCE

APPROVAL OF MINUTES: July 10, 2023

PUBLIC HEARINGS:

6:01 p.m. None

NEW BUSINESS:

1. Erik Grams of Touchdown Tile and Richards Carpet + Flooring, requesting Commercial Site Plan approval to construct an 8,400 square foot office/warehouse building addition to an existing 1,300 square foot building at 15555 Baltimore Street NE. PID# 20-32-23-12-0025.

COMMISSION BUSINESS:

1. City Council Update

CITY OF HAM LAKE
PLANNING COMMISSION MINUTES
MONDAY, JULY 10, 2023

The Ham Lake Planning Commission met for its regular meeting on Monday, July 10, 2023 in the Council Chambers at Ham Lake City Hall located at 15544 Central Avenue NE in Ham Lake, Minnesota.

MEMBERS PRESENT: Commissioners Brian Pogalz, Kyle Lejonvarn, Jeff Entsminger, Scott Heaton, Jonathan Fisher and Erin Dixon

MEMBERS ABSENT: Commissioner Dave Ringler

OTHERS PRESENT: City Engineer Dave Krugler, Building and Zoning Official Mark Jones and Building and Zoning Clerk Jennifer Bohr

CALL TO ORDER: Chair Pogalz called the meeting to order at 6:00 p.m.

PLEDGE OF ALLEGIANCE:

The pledge of allegiance was recited by all in attendance.

APPROVAL OF MINUTES:

Motion by Pogalz, seconded by Fisher, to approve the minutes of the June 26, 2023 Planning Commission meeting minutes as written. All present in favor, motion carried.

NEW BUSINESS:

Josh Williams, Structural Buildings, requesting Commercial Site Plan approval to construct a 9,352 square foot office/warehouse building for H&H Contracting at 15454 Central Avenue NE

Mr. Josh Williams and Mr. Eric Hagen were present. Mr. Williams stated H&H Contracting has currently outgrown their current location and needs additional space. Mr. Williams stated the site the new building will be constructed on was previously a single-family home. Chair Pogalz asked Building and Zoning Official Jones to comment. Building and Zoning Official Jones stated the screening on the west side of the parcel looks adequate now due to the leaves on the trees; in the fall when the leaves drop from the trees, it may not be. Building and Zoning Official Jones stated if other vegetation on the west side of the parcel provides adequate screening after the leaves drop from the trees, he does not believe it will be necessary for H&H Contracting to spend additional money on screening. Building and Zoning Official Jones stated that if screening is found to be inadequate after the leaves fall from the trees, H&H Contracting will need to put screening in place to be in compliance with City Code. Chair Pogalz asked Engineer Krugler to comment.

Engineer Krugler stated H&H Contracting will need to sign an encroachment agreement that is being prepared by the City Attorney for a storm pipe that is within a city drainage and utility easement for the proposed driveway and retaining wall. Engineer Krugler stated an NPDES permit has not been received and will be needed before any grading can be done on the site. Commissioner Lejonvarn completed the inspection; a copy which is on file. Commissioner Lejonvarn stated he met with Mr. Williams at the site. Commissioner Lejonvarn stated the west lot line has a great deal of vegetation on it consisting of some tall pine trees and a lot of small trees and brush. Commissioner Lejonvarn stated H&H Contracting has discussed constructing a fence to the west of the filtration basin, but space is limited due to easements. Commissioner Lejonvarn stated he drove to the cul-de-sac near 1255 154th Avenue NE to observe what would be visible to the residents to the west of the site. Commissioner Lejonvarn stated screening is sufficient now though there was some visibility to the site from that location; screening should be re-evaluated in the fall. Chair Pogalz asked Mr. Hagen what plans he had for screening. Mr. Hagen stated landscaping is his business and if screening is needed he would put screening in to comply with City Code. Commissioner Lejonvarn stated the front or east side of the property has a couple hard wood trees and will have a flag pole and retaining wall. Commissioner Lejonvarn stated one to two trees could be added to the eastern side of the property but stated screening should be limited in the right-of-way area as to not block the view of the building. Commissioner Heaton asked how the screening issue should be addressed. Building and Zoning Official Jones stated a temporary certificate of occupancy could be issued and H&H Contracting would have to post financial security if the screening is not adequate in the fall; a final certificate of occupancy would not be issued until screening meets City Code requirements. Commissioner Dixon asked if anyone has talked with the residents to the west. Mr. Hagen stated he has and the neighbors are excited about the project. Mr. Hagen stated he asked the residents about screening and what type of fence they would prefer if a fence was constructed. Mr. Hagen stated the residents are amenable to any fence material choice H&H Contracting makes. Building and Zoning Official Jones stated if a fence is chosen for screening, the fence height should be considered as large equipment, such as a front-end loader, would be parked within a fenced in area. Mr. Hagen stated they have not decided if screening will be vegetation or fence. Building and Zoning Official Jones stated if H&H Contracting decides to use vegetation for screening, the vegetation must be conifers of sufficient size and proximity to provide an intermingled screen within five years. **Motion by Lejonvarn, seconded by Entsminger, to recommend approval of Josh William's request for Commercial Site Plan approval to construct a 9,352 square foot office/warehouse building for H&H Contracting at 15454 Central Avenue NE subject to adding two trees along the right-of-way line of the public roadway, complying with the screening requirements of the Building and Zoning Official for the west side of the parcel, meeting the requirements of the City Engineer and the Building Official, and meeting all City, County and State requirements. All present in favor, motion carried. This application will be placed on the City Council's Monday, July 17, 2023 agenda.**

COMMISSION BUSINESS:

City Council Update

Commissioner Fisher stated the City Council concurred with the Planning Commission's recommendations to approve the Preliminary and Final Plat of Toby's Trails, the Preliminary Plat of Hidden Forest East Fourth Addition and the Commercial Site Plan approval for Jam Hops. A Planning Commissioner will not be present at the July 17, 2023 City Council meeting.

ADJOURNMENT:

Motion by Heaton, seconded by Fisher, to adjourn the Planning Commission meeting at 6:16 p.m. All present in favor, motion carried.

Jennifer Bohr
Building and Zoning Clerk

**CITY OF HAM LAKE
PLANNING COMMISSION REQUEST APPLICATION
INSPECTION REPORT**

MTG DATE: 8/14/2023

INSPECTION ISSUED TO: Brian Pogalz

APPLICANT/CONTACT: Erik Grams

TELEPHONE NUMBER: 612-747-3605 or erik@touchdowntile.com

BUSINESS/PLAT NAME: Touchdown Tile/Richards Carpet + Flooring

ADDRESS/LOCATION OF INSPECTION: 15555 Highway 65 NE/15555 Baltimore St NE

APPLICATION FOR: Commercial Building Permit

RECOMMENDATION: _____

DATE: _____

PLANNING COMMISSIONER SIGNATURE: _____



RECEIVED
 JUL 13 2023
 By:

CITY OF HAM LAKE

15544 Central Avenue NE

Ham Lake, MN 55304

Phone (763) 434-9555 Fax (763) 235-1697

PLANNING REQUEST

Date of Application 7/13/2023

Date of Receipt 7-13-23

Receipt # 96685

Meeting Appearance Dates:

Planning Commission 8/14/23

City Council 11

Please check request(s):

- Metes & Bounds Conveyance
- Sketch Plan
- Preliminary Plat Approval*
- Final Plat Approval
- Rezoning*
- Multiple Dog License*

- Commercial Building Site
- Certificate of Occupancy
- Home Occupation Permit
- Conditional Use Permit (New)*
- Conditional Use Permit (Renewal)
- Other

***NOTE: Advisory Signage is required for land use alterations and future road connections. This application also requires a Public Hearing. Such fees shall be deducted from deposit.**

Development/Business Name: Touchdown and Richards LLC

Address/Location of property: 15555 Hwy 65 NE, Ham Lake, MN 55304

Legal Description of property: Metes & Bounds

PIN # 20-32-23-12-0025 Current Zoning CO-1 Proposed Zoning ---

Notes: 8,400 sq ft bldg addition to existing 1,300 sq ft bldg Office Warehouse with retail space. Future address:

Applicant's Name: Erik Grams 15555 Baltimore St

Business Name: Touchdown and Richard's

Address 13837 Lincoln St NE

City Ham Lake State MN Zip Code 55304

Phone (612) 747-3605 Cell Phone _____ Fax _____

Email address erik@touchdownfile.com

You are advised that the 60-day review period required by Minnesota Statutes Chapter 15.99 does not begin to run until all of the required items have been received by the City of Ham Lake.

SIGNATURE [Signature] DATE 7/13/2023

- FOR STAFF USE ONLY -

ACTION BY: Planning Commission _____
 City Council _____

PROPERTY TAXES CURRENT YES NO



Narrative of businesses that will occupy 15555 Hwy 65 NE, Ham Lake, MN



Richards Carpet + Flooring

Hello,

Two businesses will occupy our space at 15555 Hwy 65 NE, Touchdown Tile and Richard's Carpet + Flooring. The existing building will be remodeled into our greeting area, offices, and gateway to the showroom. The addition we will be building is for the showroom, additional offices, and warehouse space.

Touchdown Tile is a licensed general contractor and our business consists of retail remodeling showroom, interior design, home remodeling, residential flooring installation, and commercial tile and hard surface installation. We have been in business since 2004. Our staff includes 10 full-time employees. Touchdown Tile's current operating hours are 7:30 AM – 4:30 PM weekdays. Touchdown will occupy approximately 2/3 of the space in the new facility and host monthly home improvement events in the existing parking lot. Touchdown Tile will have approximately 2,000 sf of warehouse space for storage.

Richards Carpet + Flooring is a retail flooring and home improvement store and installation company which has been in business for over 45 years as Richard Blaido is a second-generation owner. The company currently has 6 employees. Their business consists of residential and commercial flooring and countertop installation. Richards Carpet current operating hours are 9:00 AM – 5:00 PM. Richards Carpet will occupy approximately 1/3 of the new facility and will have approximately 1,000 SF of warehouse space for storage.

Thank you for considering our project. On behalf of both of our companies we are excited to continue working in Ham Lake.

Sincerely,

Erik Grams

Owner

Touchdown Tile

CITY OF HAM LAKE
STAFF REPORT

To: Members of the Planning Commission

From: Mark Jones, Building and Zoning Official

Subject: Touchdown Tile & Richards Carpet + Flooring, requesting site plan approval to build a new 8,400 square foot office/warehouse building at 15555 Baltimore Street NE

Introduction/Discussion:

Touchdown Tile is a licensed general contractor providing services of interior design, home remodeling, and tile and hard surface flooring installation for both residential and commercial buildings. Richards Carpet + Flooring is a retail flooring and home improvement store providing installation services for flooring and counter tops for residential and commercial buildings. Touchdown Tile has been in business since 2004 and employs 10 full-time employees. Richards Carpet + Flooring has been in business for over 45 years and employees 6 people.

Touchdown Tile and Richards Carpet + Flooring are proposing to construct an 8,400 square foot new, warehouse building that will connect to an existing 1,300 square foot building. The existing building will be a greeting area, with office space and showroom. The new addition will have a showroom, office space and warehouse space. Business hours will be Monday – Friday, 7:30 am to 5 pm. Erik has expressed interest in expanding retail hours to 7:00 am to 5:00 pm in the future. Consideration is also being given to being open on Saturdays and Sundays.

The architectural plans submitted to the City propose a pole structure which does not meet the construction standards for Building Construction in Commercial Development I (CD-1) Zoning. Per Article 9-220.2.a.i *except for structures housing public utility feature, no metal or pole-type building shall be permitted.* The existing building does meet the CD-1 construction standard, but will need to meet the Building Code for frost footings. The applicant is in the process of providing the City with architectural and engineered building plans that will be code compliant.

Recommendation:

I recommend site plan approval for Touchdown Tile & Richards Carpet + Flooring with the following conditions:

- 1) The applicant submits architectural building plans, with engineering, that meets Article 9-220.2 a, standards for site and building construction for CD-1 zoning.
- 2) The parking spaces and septic system meet the maximum occupancy load of the building.
- 3) Identifying an area for the trash enclosure and submitting a design for the enclosure
- 4) Ground work cannot begin until a Coon Creek Watershed District permit and National Pollutant Discharge Elimination system (NPDES) permit have been issued.
- 5) Meeting all other City and State codes.

All of the items noted above must be received before a building permit can be issued.

Memorandum

Date: August 10, 2023
To: Planning Commissioners
From: David A. Krugler, City Engineer 
Subject: Touchdown Tile

Introduction:

The proposed 8,400 square-foot Touchdown Tile building is located on the 2.88-acre 15555 Baltimore Street NE. The parcel is zoned Commercial Development Tier 1 (CD-1). A 100-scale aerial photo, a 500-scale zoning map and a 400-scale half section map are attached.

Discussion:

The Title Sheet, Civil Legend, Civil Details, Existing Conditions and Removal Plan, Site Plan, Grading and Drainage Plan, Turf Establishment and Erosion Control Plan and Storm Water Pollution Prevention Plan were received August 9th address prior review comments.

The parcel is within 1,000 feet of Ham Lake which is defined as a Recreational Development Lake by the DNR. The plans comply with Shoreland Ordinance 92-35, portions of which are attached, including the 25-percent maximum impervious surface coverage per 12-5.52A. Per the current plans, this requirement is met. 12-5.61B of the Shoreland Ordinance requires the parcel to be 150 feet from the Ordinary High-Water Level or provide substantial screening. Ham Lake Park is between Touchdown Tile and Ham Lake.

The attached Landscape Plan which was received on August 9th, shows no trees to the west of the proposed building. Per 11-1853(B) of the City code, decorative trees shall be planted along the right-of-way lines of adjacent public roadways. 11-1860 allows for case-by-case evaluation for landscape approval and "strict adherence to the remaining provisions of Article 11-1800 may be unnecessary where size, spatial relationships, topography or other physical features render a given landscaping plan aesthetically acceptable, and departures from the strict observance of the elements of Article 11-1800 shall not be considered variances requiring a showing of physical hardship. Conversely, an applicant shall be expected to meet the general spirit of this article in establishing an aesthetically pleasing landscaping plan". A determination needs to be made as to whether the proposed Landscaping is adequate where adjacent to Ham Lake Park and the City Right-of-Way or if additional screening is required.

The Touchdown Tile project was conditionally approved by the Coon Creek Watershed District (CCWD) Board of Managers at their July 24th meeting. The Notice of Application Status is attached. The execution of an Operation and Maintenance Agreement for storm water treatment is required to obtain the CCWD Permit. A CCWD permit is required before grading operations can commence. A Minnesota Pollution Control Agency National Pollutant Discharge

Elimination System Construction Stormwater Permit is also required before grading operations can commence because the disturbed area is over one-acre.

The City of Ham Lake constructed Baltimore Street NE from 153rd Avenue to 159th Avenue in 2012. In order to accomplish this, property was acquired from multiple owners along Baltimore Street NE to satisfy the MnDOT 60-foot minimum right-of-way width. In order to facilitate the purchase of property along Baltimore Street NE, language was added to the purchase agreement between the City and land owners. This was to allow future developments to accommodate certain restrictions imposed on the property owner by the road project. The attached portion of the purchase agreement specifies that certain variances are permitted, including setbacks. Currently the City has a 10-foot setback requirement for all signs and parking in the right-of-way. The billboard, sign posts and portions of the proposed parking are within this 10-foot setback area. A variance for allowing the existing signs and proposed parking within the setback area is included.

Recommendation:

It is recommended that the Touchdown Tile commercial site plan and variance be recommended for approval, including the determination if the proposed screening is adequate.

BALTIMORE ST

15635

15625

15615

15605

15555

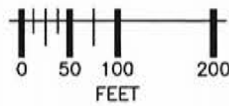

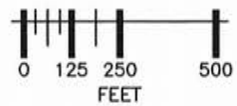
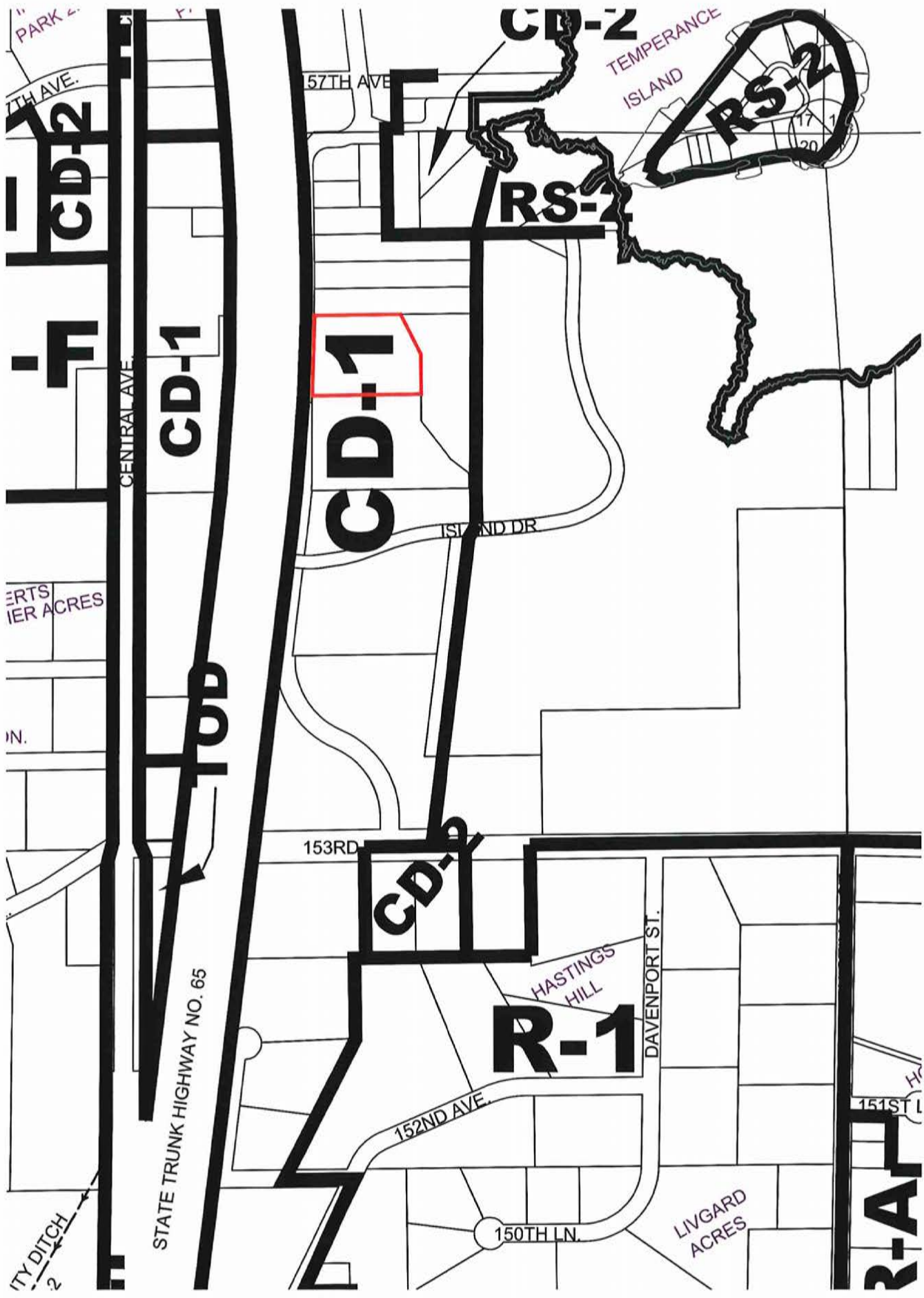

N 1/2 SECTION 20, T. 32, R. 23

CITY OF HAM LAKE

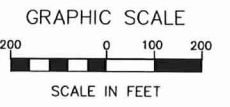

ANOKA COUNTY
SURVEYOR'S OFFICE
ROOM 224
2100 3RD AVENUE
ANOKA, MN 55303
(763) 324-3200

QUARTER QUARTER INDEX

22	21	12	11
23	24	13	14
NORTH HALF OF SECTION			
32	31	42	41
33	34	43	44
SOUTH HALF OF SECTION			

PROPERTY IDENTIFICATION NUMBER

Section Number	Township Number	Range Number	Quarter Number	Specific Parcel
XX	XX	XX	XX	XXXX

SPECIFIC PARCEL NUMBERS ARE IN BRACKETS: [1]
EXAMPLE OF PIN NUMBER: 20-32-23-13-010

THIS IS A COMPILATION OF RECORDS AS THEY APPEAR IN THE ANOKA COUNTY OFFICES AFFECTING THE AREA SHOWN. THIS DRAWING IS TO BE USED ONLY FOR REFERENCE PURPOSES AND THE COUNTY IS NOT RESPONSIBLE FOR ANY INACCURACIES HEREIN CONTAINED.

TOUCHDOWN TILE - BUILDING EXPANSION PROJECT

HAM LAKE, MN



PROJECT LOCATION
TOUCHDOWN TILE
15555 BALTIMORE STREET NE

PROJECT LOCATION
CITY OF HAM LAKE

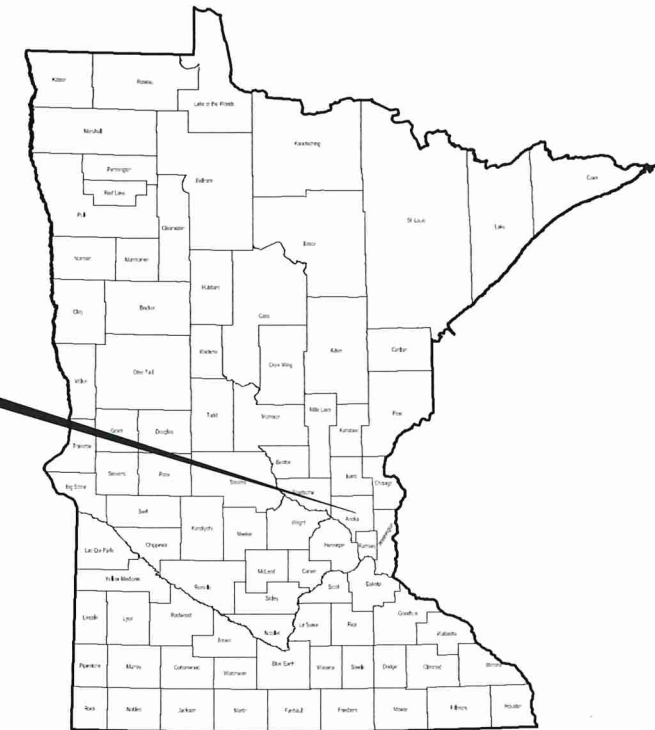

DRAWING INDEX	
SHEET NUMBER	SHEET TITLE
C1.0	TITLE SHEET
C2.0	CIVIL LEGEND
C3.0 - C3.1	CIVIL DETAILS
C4.0	EXISTING CONDITIONS & REMOVAL PLAN
C5.0	SITE PLAN
C6.0	GRADING AND DRAINAGE PLAN
C7.0	TURF ESTABLISHMENT AND EROSION CONTROL PLAN
C8.0 - C8.1	STORM WATER POLLUTION PREVENTION PLAN
L1.0	LANDSCAPE PLAN

GOVERNING SPECIFICATIONS

THE 2020 EDITION OF THE MINNESOTA DEPARTMENT OF TRANSPORTATION "STANDARD SPECIFICATIONS FOR CONSTRUCTION" AND 2020 EDITION OF THE "MATERIALS LAB SUPPLEMENTAL SPECIFICATIONS FOR CONSTRUCTION" SHALL GOVERN.

I HEREBY CERTIFY THAT THIS PLAN, SPECIFICATION, OR REPORT WAS PREPARED BY ME OR UNDER MY CLOSE PERSONAL SUPERVISION AND THAT I AM A DULY LICENSED PROFESSIONAL ENGINEER UNDER THE LAWS OF THE STATE OF MINNESOTA.

Frank E. Brodeen
FRANK E. BRODEEN LIC. NO. 57790

DATE	REVISION DESCRIPTION	BY

DATE: AUGUST 2023
SCALE: AS SHOWN
DRAWN BY: TJH
CHECKED BY: TJH
JOB NUMBER: 2023-10749

15555 BALTIMORE ST NE - PROPOSED BUILDING EXPANSION
HAM LAKE, MN
ANOKA COUNTY
TITLE SHEET

SURVEY MONUMENTS

- BENCH MARK
- FOUND CIM
- FOUND CPNT.
- FOUND JLM
- FOUND LATH
- FOUND PIPE
- FOUND READING
- STAKED CIM
- STAKED CPNT.
- STAKED JLM
- STAKED PIPE

EXISTING TOPO SYMBOLS

- AC UNIT
- FENCE POST
- FLAG POLE
- GUARD POST
- GUY ANCHOR
- GUY POLE
- HANDICAP SYMBOL
- MAILBOX
- SHRUB
- SIGN DOUBLE POST
- SIGN SINGLE POST
- SIGN FIRE NUMBER
- TREE CONIFER
- TREE DECIDUOUS
- TREE STUMP
- TV DISH
- WETLAND SYMBOL
- YARD LIGHT

EXISTING UTILITY MUNICIPAL SYMBOLS

- APRON
- LIFT STATION
- SANITARY CLEANOUT
- SANITARY MANHOLE
- STORM CATCH BASIN
- STORM INLET

EXISTING UTILITY MUNICIPAL SYMBOLS (cont.)

- STORM MANHOLE
- WATER CURB STOP
- WATER HANDHOLE
- WATER HYDRANT
- WATER MANHOLE
- WATER METER
- WATER VALVE
- WATER WELL

EXISTING UTILITY PRIVATE SYMBOLS

- ELEC GROUND LIGHT
- ELEC HANDHOLE
- ELEC LIGHT POLE
- ELEC MANHOLE
- ELEC METER
- ELEC PEDESTAL
- ELEC POLE
- ELEC SIGNAL
- ELEC TRANSFORMER BOX
- GAS METER
- GAS VALVE
- LP TANK
- TELE HANDHOLE
- TELE MANHOLE
- TELE PEDESTAL
- TELE POLE
- TV HANDHOLE
- TV PEDESTAL

SOIL BORING SYMBOLS

- LASER-INDUCED FLUORESCENCE BORING
- LYSIMETER
- MONITOR WELL
- PERC TEST
- PIEZOMETER
- RECOVERY WELL
- SOIL BORING
- SOIL VAPOR POINT
- VAPOR SURVEY POINT

PROPOSED UTILITY MUNICIPAL SYMBOLS

- APRON PROPOSED
- SANITARY CLEANOUT PROPOSED
- SANITARY LIFT STATION PROPOSED
- SANITARY LIFT STATION VALVE MANHOLE PROPOSED
- SANITARY MANHOLE PROPOSED
- SANITARY PLUG PROPOSED
- STORM CATCH BASIN PROPOSED
- STORM MANHOLE PROPOSED
- WATER 11 1/4° BEND PROPOSED
- WATER 22 1/2° BEND PROPOSED
- WATER 45° BEND PROPOSED
- WATER 90° BEND PROPOSED
- WATER CAP PROPOSED
- WATER CROSS PROPOSED
- WATER CURB STOP PROPOSED
- WATER HYDRANT PROPOSED
- WATER REDUCER PROPOSED
- WATER SLEEVE PROPOSED
- WATER TEE PROPOSED
- WATER VALVE PROPOSED

PROPOSED UTILITY PRIVATE SYMBOLS

- ELEC LIGHT POLE PROPOSED

EROSION CONTROL SYMBOLS

- SURFACE DRAINAGE ARROW
- STORM DRAIN INLET PROTECTION

TRAFFIC CONTROL DEVICES & SYMBOLS

- TRAFFIC CONTROL SIGN (1 POST)
- TRAFFIC CONTROL SIGN (2 POST)
- TYPE III BARRICADE
- DRUM CHANNELIZER
- FLASHING ARROW OR MESSAGE BOARD

EXISTING TOPOGRAPHIC LINES

- CENTER LINE
- EDGE OF WOODS
- FENCE BARB WIRE
- FENCE CHAIN LINK
- FENCE WOOD
- FORCEMAIN
- OVERHEAD CABLE TV
- OVERHEAD ELECTRIC
- OVERHEAD TELE
- RAILROAD
- RETAINING WALL
- SANITARY SEWER
- SANITARY SEWER SERVICE
- STORM SEWER
- STORM SEWER DRAIN TILE
- UNDERGROUND CABLE TV
- UNDERGROUND ELECTRIC
- UNDERGROUND FIBER OPTIC
- UNDERGROUND GAS
- UNDERGROUND TELE
- WATERMAIN
- WATERMAIN SERVICE
- WETLAND EDGE

R/W, LOT & EASEMENTS LINES

- BUILDING SETBACK LINE
- LOT LINE PROPOSED
- EASEMENT LINE
- EASEMENT LINE PROPOSED
- LOT LINE
- MNDOT CONTROLLED ACCESS LINE
- RIGHT OF WAY EXISTING
- RIGHT OF WAY PROPOSED

PROPOSED CONSTRUCTION LINES

- FENCE CHAIN LINK PROPOSED
- FENCE WOOD PROPOSED
- FENCE BARB WIRE PROPOSED
- FORCEMAIN PROPOSED
- SANITARY SEWER PROPOSED
- SANITARY SERVICE PROPOSED
- STORM SEWER PROPOSED
- STORM SEWER DRAIN TILE PROPOSED
- WATERMAIN PROPOSED
- WATERMAIN SERVICE PROPOSED

EROSION CONTROL LINES

- BALE CHECK
- BIO ROLL
- SILT FENCE
- SILT FENCE TYPE HEAVY DUTY
- SILT FENCE TYPE MACHINE SLICED
- SILT FENCE TYPE PREASSEMBLED
- FLOTATION SILT CURTAIN

HATCH PATTERN AND SHADING LEGEND

- RANDOM RIPRAP
- SOD
- SEED
- HYDRAULIC STABILIZER
- EROSION CONTROL BLANKET
- TEMP. ROCK CONSTRUCTION ENTRANCE
- BUILDING WALL HATCH
- BITUMINOUS SURFACE
- CONCRETE SURFACE
- GRAVEL SURFACE
- EASEMENT PATTERN

DOCUMENTATION SYMBOLS

- SECTION ARROW - SECTION NUMBER TOP, PAGE OF SECTION BOTTOM

DRAFT - NOT FOR CONSTRUCTION

I HEREBY CERTIFY THAT THIS PLAN, SPECIFICATION, OR REPORT WAS PREPARED BY ME OR UNDER MY CLOSE PERSONAL SUPERVISION AND THAT I AM A DULY LICENSED PROFESSIONAL ENGINEER UNDER THE LAWS OF THE STATE OF MINNESOTA

REVISION DESCRIPTION	DATE	REVIEW

DATE: AUGUST 2023	SCALE: AS SHOWN
DRAWN BY: FEB	CHECKED BY: THH
JOB NUMBER: 2023-10749	

15555 BALTIMORE ST NE - PROPOSED BUILDING EXPANSION
HAM LAKE, MN
ANOKA COUNTY

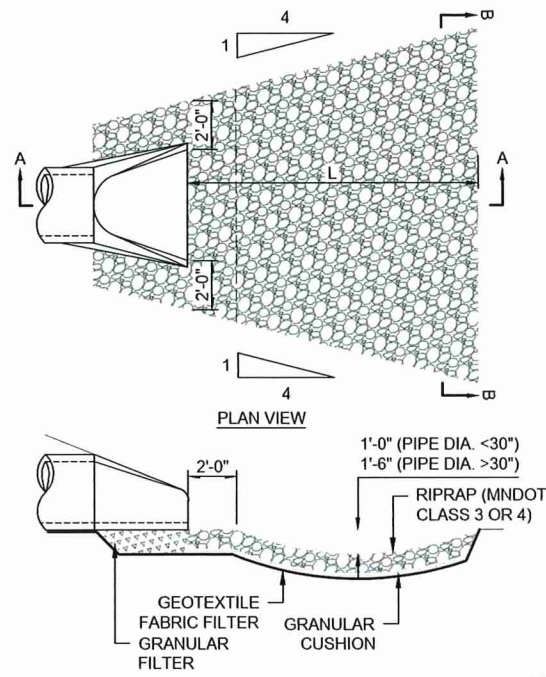

RIPRAP LENGTHS	
DIA. OF PIPE (IN.)	LENGTH OF RIPRAP (FT.)
12	8
15	8
18	10
21	10
24	12
27	12
30	14
36	16
42	18
48	20

RIPRAP LENGTHS	
SPAN OF PIPE ARCH (IN.)	LENGTH OF RIPRAP (FT.)
22	10
28	12
36	14
43	16
51	18
58	20

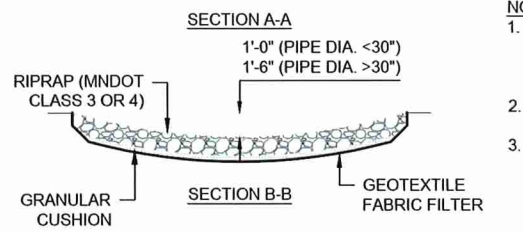

- NOTES:**
1. GEOTEXTILE FILTER, MNDOT SPEC. 3733, SHALL COVER THE BOTTOM & SIDES OF THE AREA EXCAVATED FOR THE RIPRAP, GRANULAR FILTER MATERIALS.
 2. GRANULAR FILTER, MNDOT SPEC. 3601, MAY BE USED AS A CUSHION LAYER.
 3. GRANULAR FILTER OR RIPRAP, MNDOT SPSC. 3601, TO EXTEND UNDER ENTIRE OPEN PORTION OF PIPE APRON. DEPTH OF MATERIAL UNDER APRON SHALL MATCH RIPRAP DEPTH.

RIPRAP AT RCP OUTLETS DETAIL
SCALE: NONE

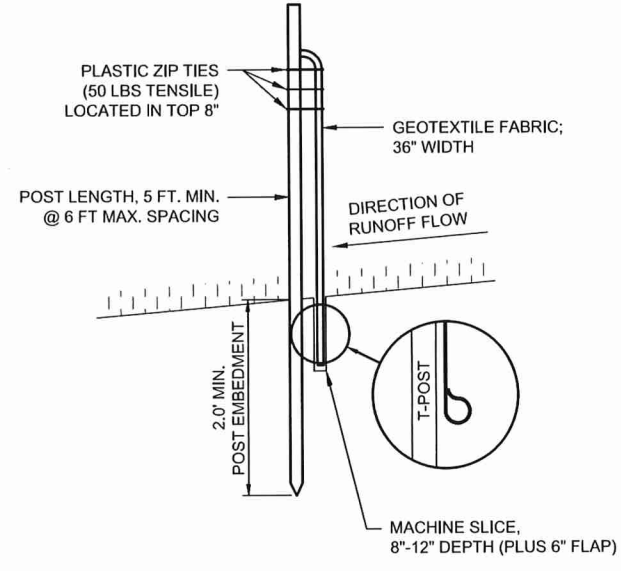

SILT FENCE DETAIL - MACHINE SLICED
SCALE: NONE

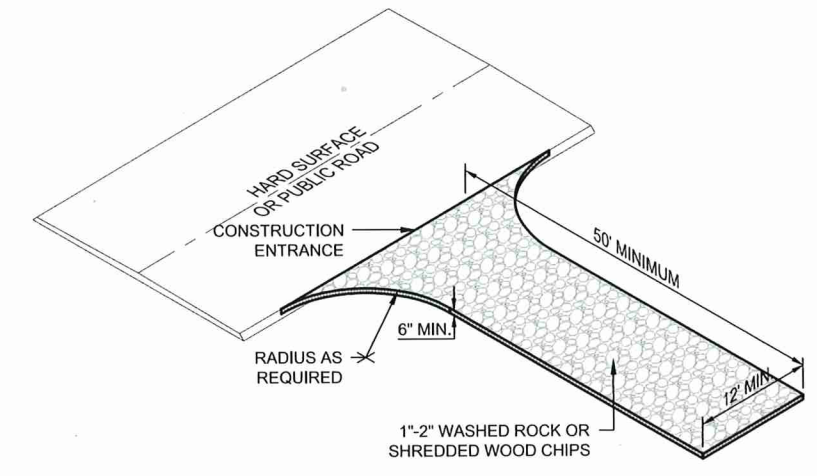

TEMPORARY ROCK CONSTRUCTION ENTRANCE
SCALE: NONE

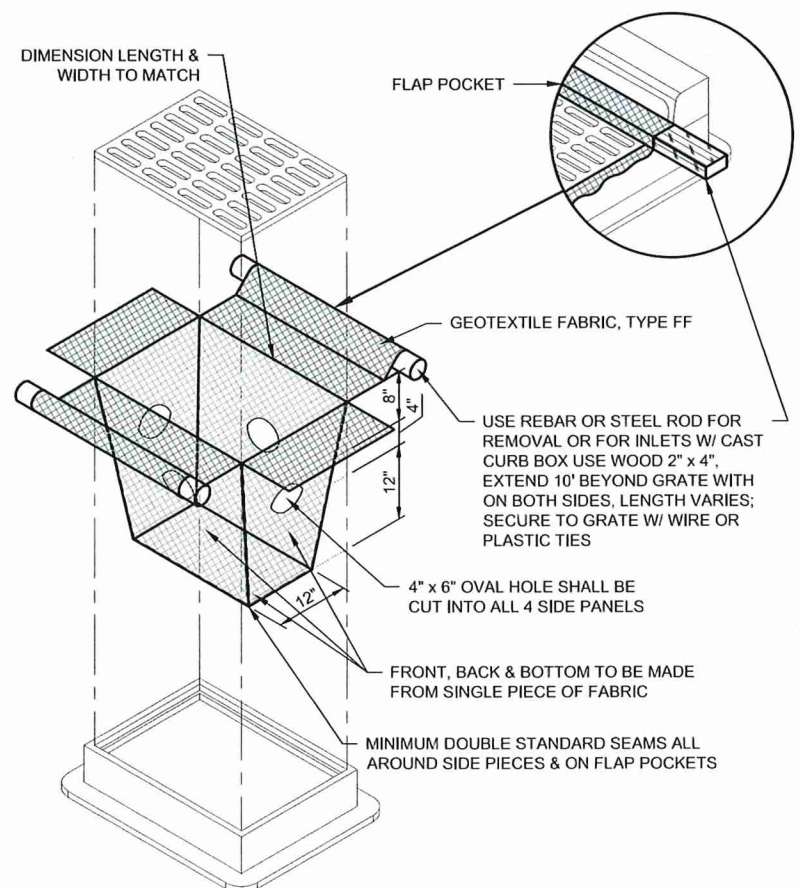

INLET PROTECTION DETAIL - FABRIC
SCALE: NONE

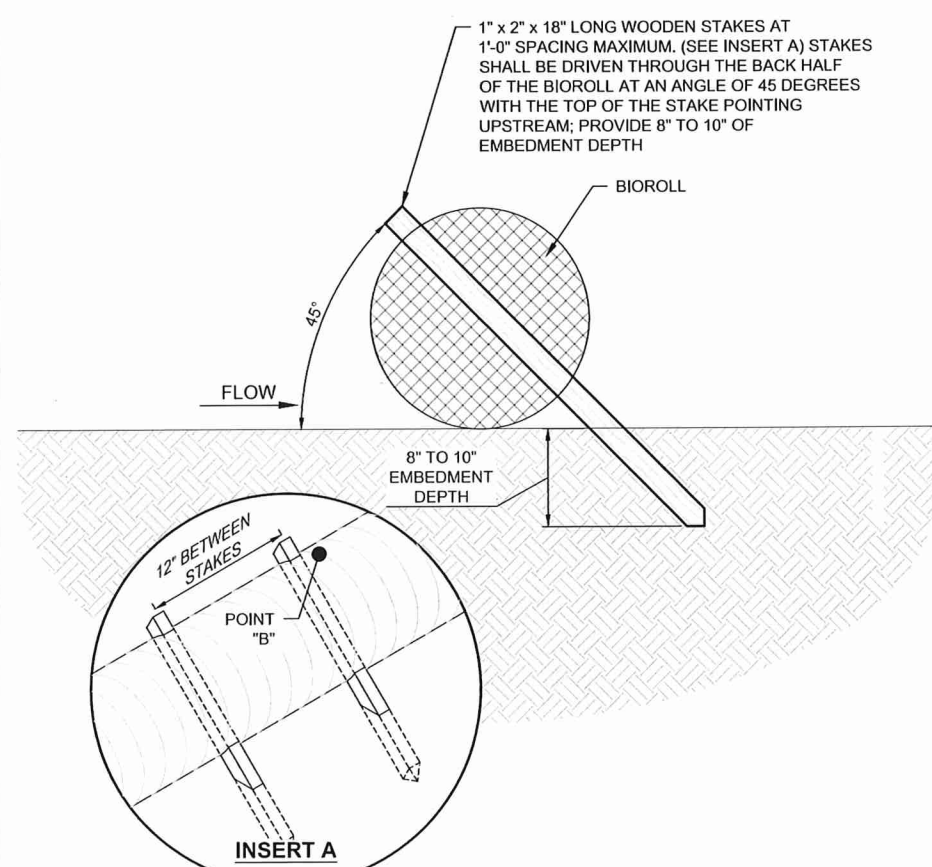

BIO-ROLL SEDIMENT CONTROL LOG STAKING DETAIL
SCALE: NONE

RECOMMENDED SPACING BETWEEN DITCH SLOPES

DITCH GRADE (%)	SPACING (FT.)
2	100
4	75
6	50
8	40
10	25

- NOTES:**
- SEE MNDOT SPECS. #2573, #3885, #3886, & #3889.
 - SPACING OF DITCH CHECKS IS DEPENDENT ON DRAINAGE AREA & GRADES.
 - POINT "A" MUST BE 1'-0" MIN. HIGHER THAN POINT "B".

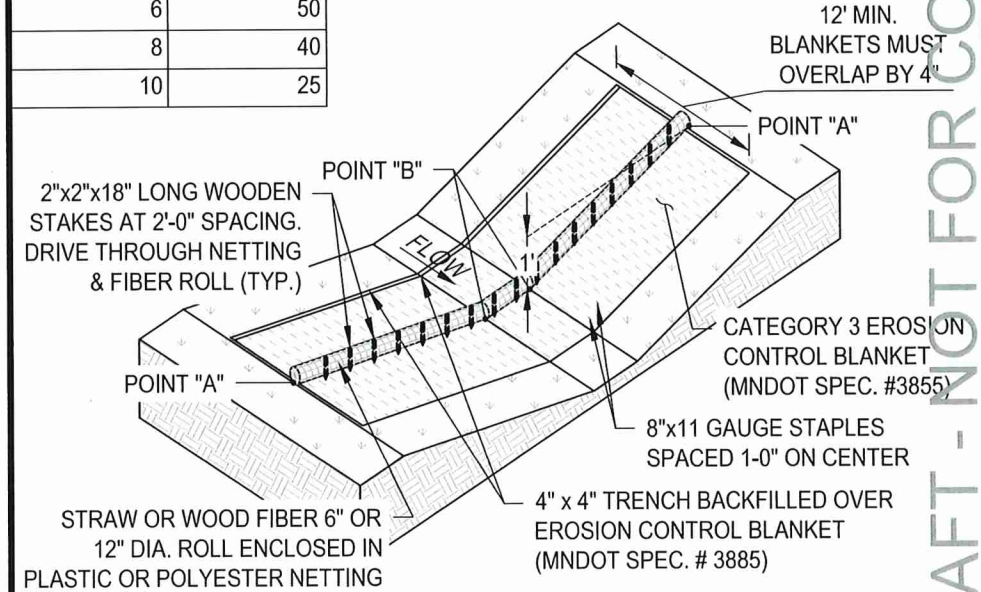

BIOROLL BLANKET SYSTEM TYPE 3, MNDOT SPEC. #3889

DRAFT - NOT FOR CONSTRUCTION

REVISIONS	DESCRIPTION	DATE	BY

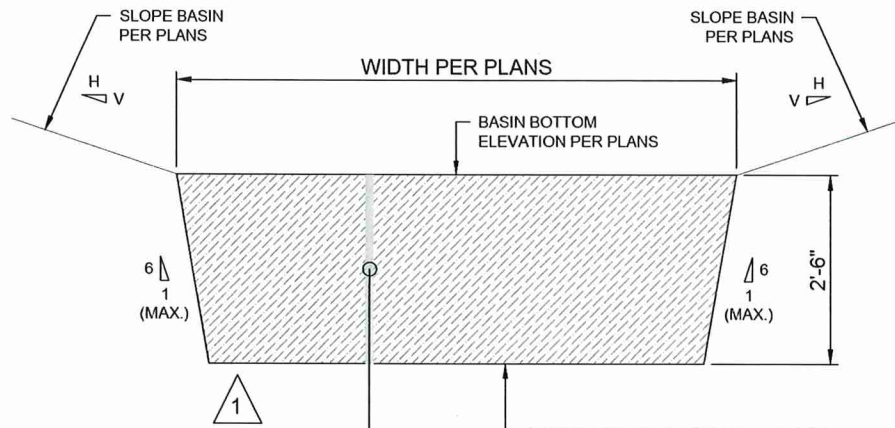

NOTES:

FINAL STABILIZATION OF CONTRIBUTING DRAINAGE AREA SHALL BE COMPLETED PRIOR TO CONSTRUCTION OF INFILTRATION BASIN. SEE GRADING AND DRAINAGE PLAN FOR CONSTRUCTION SEQUENCING INFORMATION.

CONTRACTOR TO AVOID COMPACTION OF INFILTRATION AREA AND INFILTRATION MEDIA DURING CONSTRUCTION.

CONTRACTOR TO PROVIDE SAMPLING AND TESTING OF FILTER TOPOIL MATERIAL PER MNDOT SPEC 3877.3

INFILTRATION BASIN SECTION DETAIL

SCALE: NONE

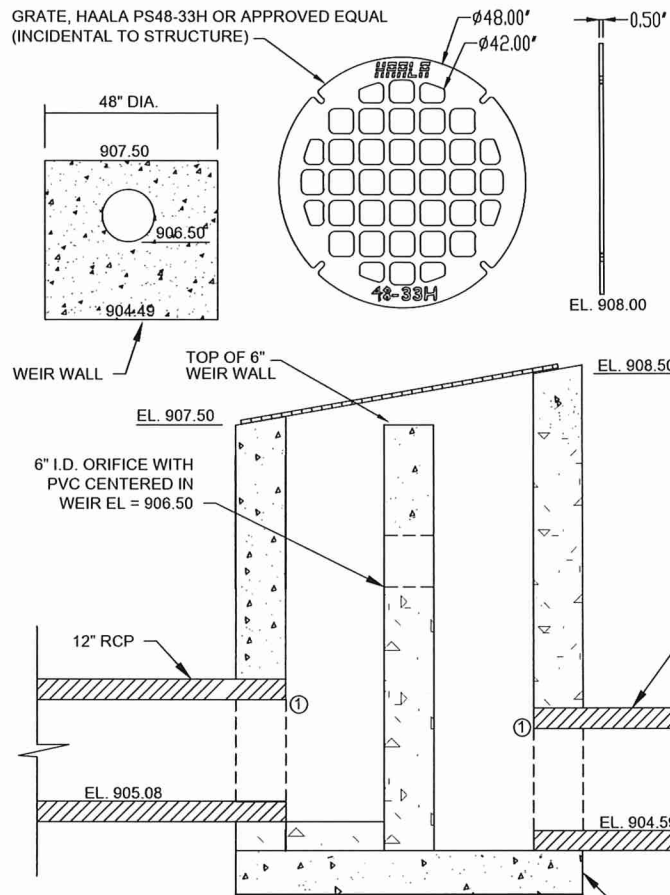

CONTROL STRUCTURE #1 DETAIL

SCALE = N.T.S. ① PROVIDE RUBBER BOOT - SEAL

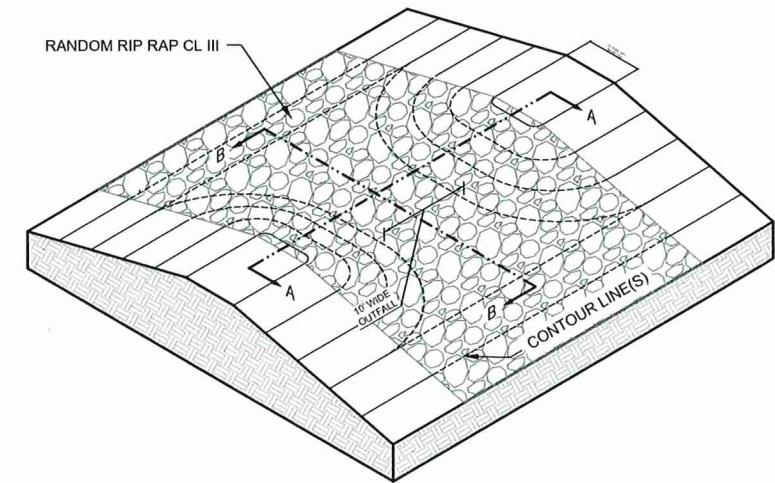

CROSS SECTION A-A

CROSS SECTION B-B

INFILTRATION BASIN EMERGENCY OVERFLOW DETAIL

SCALE: NONE

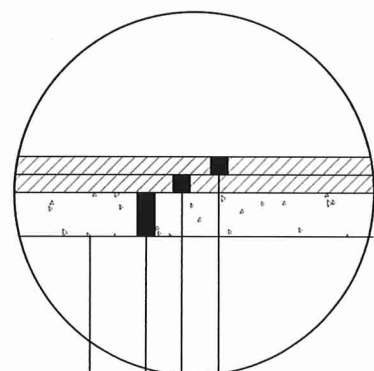

PROPOSED BITUMINOUS PAVEMENT SECTION

(NOT TO SCALE)

THE FOLLOWING STANDARD PLATES, APPROVED BY THE FEDERAL HIGHWAY ADMINISTRATION, SHALL APPLY ON THIS PROJECT.

MnDOT STANDARD PLATES	
3000L	REINFORCED CONCRETE PIPE
3006G	GASKET JOINT FOR R.C. PIPE
4011E	PRECAST CONCRETE BASE
4020J	MANHOLE OR CATCH BASIN
4022A	MANHOLE OR CATCH BASIN COVER
4026A	CONCRETE ENCASED CONCRETE ADJUSTING RINGS
4180J	MANHOLE OR CATCH BASIN STEP
7111J	INSTALLATION OF CATCH BASIN CASTINGS

MnDOT STANDARD PLANS MANUAL	
5-297.404	PERMANENT EROSION CONTROL
5-297.405	TEMPORARY SEDIMENT CONTROL
5-297.405	TEMPORARY EROSION CONTROL SILT FENCE
5-297.406	PERMANENT SEDIMENT CONTROL
5-297.422	STANDARD STORM SEWER BEDDING FOR RIGID AND FLEXIBLE PIPE

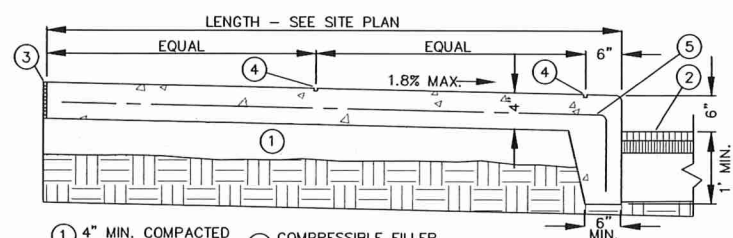

- ① 4" MIN. COMPACTED AGGREGATE BASE CLASS 5
- ② PAVEMENT
- ③ COMPRESSIBLE FILLER (3/4" MAXIMUM). CUT BACK AND PROVIDE SEALANT, TYPICAL, AT ALL JOINTS WITH FILLER.
- ④ 1/4" TOOLED JOINT
- ⑤ 6" X 6" #10 W.W.F.

THICKENED EDGE CONCRETE DETAIL (NOT TO SCALE)

STAND ALONE CONCRETE VALLEY GUTTER DETAIL

(NOT TO SCALE)

SAFL BAFFLE SIZING REQUIREMENTS

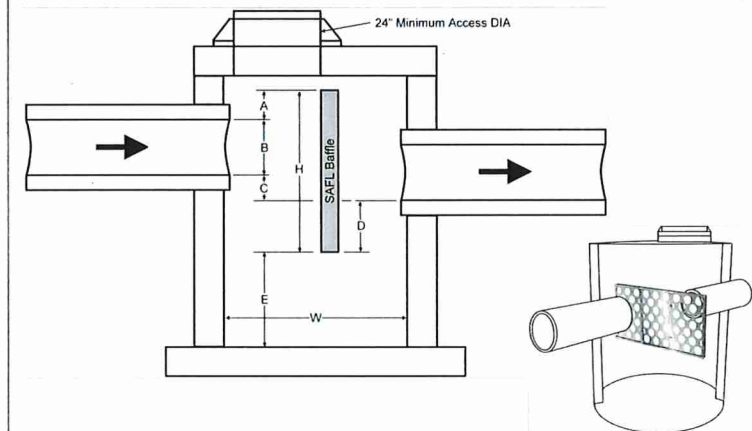

A	6"
B	Inlet pipe inside diameter = 15"
C	1"
D	12"
E	48"
W	48"
H	36"
Purchase Baffle Size	W x H View the complete list of Available Baffle Sizes
	Also see: Bracing Guide & Slacking Guide
NOTE 1	If H is greater than 57" two SAFL Baffles may be stacked.
NOTE 2	75% of flow must be horizontal. No more than 25% falling from above
NOTE 3	This detail does not cover sizing the sump for sediment removal efficiency. Contact Upstream for sump sizing or use SHSAM Software
NOTE 4	For more information, see our Design Guide

PATENT PROTECTED Patents: US #8663466B2 - US #8715507B2 - US #9506237B2 - CA #2742207

This generic detail does not encompass the sizing, fit, and applicability of the SAFL Baffle for this specific project. It is the ultimate responsibility of the design engineer to assure that the design is in compliance with all applicable laws and regulations. The SAFL Baffle is a patented technology of Upstream Technologies, Inc. Upstream Technologies does not approve plans, sizing, or system designs.

SAFL BAFFLE SIZING DETAIL
UPSTREAM TECHNOLOGIES INC.
5201 EAST RIVER ROAD, SUITE 303
FRIDLEY, MN 55421
651-237-5123



DATE: 8/02/2023 LIC. NO. 57780
FRANK E. BRODEEN

REVISION DESCRIPTION	DATE	BY
1 REMOVE FABRIC FROM RASHI DETAIL	8/30/2023	FER

DATE	SCALE	DRAWN BY	CHECKED BY	JOB NUMBER
AUGUST 2023	AS SHOWN	FER	TJH	2023-10749

15555 BALTIMORE ST NE - PROPOSED BUILDING EXPANSION
HAM LAKE, MN
ANOKA COUNTY
CIVIL DETAILS

DRAFT - NOT FOR CONSTRUCTION

PARID: 20-32-23-12-0025
 15555 BALTIMORE ST NE
 HAM LAKE, MINNESOTA 55304
 ZONE: COMMERCIAL - TIER 1 (CD-1)

OWNER: TOUCHDOWN AND RICHARDS LLC
 13837 LINCOLN ST NE
 HAM LAKE, MN 55304
 CONTACT: ERIK GRAMS
 EMAIL: ERIK@TOUCHDOWN TILE.COM
 PH: (612)-747-3605

CIVIL ENGINEER: WIDSETH (WIDSETH SMITH NOLTING)
 5368 266TH ST
 WYOMING, MN 55092
 CONTACT: FRANK BRODEEN, PE
 EMAIL: FRANK.BRODEEN@WIDSETH.COM
 PH: (651)-358-2345

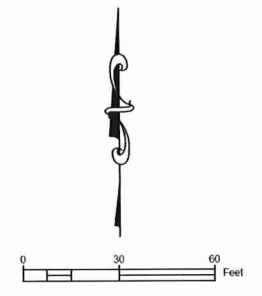

GENERAL CONSTRUCTION NOTES:

THE CONTRACTOR SHALL VERIFY ALL EXISTING CONDITIONS PRIOR TO CONSTRUCTION AND NOTIFY OWNER OF ANY DIFFERENCES BETWEEN THE FIELD AND PLAN.

THE SUBSURFACE UTILITY INFORMATION IN THIS PLAN IS UTILITY QUALITY LEVEL D. THIS QUALITY LEVEL WAS DETERMINED ACCORDING TO THE GUIDELINES OF CHASCE 38-02 ENTITLED "STANDARD GUIDELINES FOR THE COLLECTION AND DEPICTION OF EXISTING SUBSURFACE UTILITY DATA".

UNLESS OTHERWISE NOTED, ALL MATERIALS, CONSTRUCTION TECHNIQUES AND TESTING SHALL CONFORM TO THE 2020 EDITION OF THE "STANDARD SPECIFICATIONS FOR TRENCH EXCAVATION AND BACKFILL/SURFACE RESTORATION, WATERMAIN AND SERVICE LINE INSTALLATION AND SANITARY SEWER AND STORM SEWER INSTALLATION" AS PUBLISHED BY THE CITY ENGINEERS ASSOCIATION OF MINNESOTA AND THE "STANDARD SPECIFICATIONS FOR CONSTRUCTION" AS PUBLISHED BY THE MINNESOTA DEPARTMENT OF TRANSPORTATION, 2020 EDITION. THE CONTRACTOR SHALL REQUIRE ALL PROCEDURES AS OUTLINED BY THE LOCAL AGENCY.

THE CONTRACTOR SHALL RECEIVE THE NECESSARY PERMISSIONS/PERMITS FOR ALL WORK LOCATED OUTSIDE OF THE MUNICIPAL RIGHT-OF-WAY AND PROPERTY LIMITS.

THE CONTRACTOR SHALL VERIFY ALL EXISTING ELEVATIONS PRIOR TO BEGINNING CONSTRUCTION.

SITE REMOVAL NOTES:

THE CONTRACTOR SHALL LOCATE ALL UTILITIES VIA A GOPHER STATE ONE CALL.

THE CONTRACTOR SHALL LOCATE PRIVATE UTILITIES, COORDINATING WITH THE OWNER.

THE CONTRACTOR SHALL INSTALL ALL EROSION CONTROL MEASURES BEFORE DISTURBING THE SITE.

CONTRACTOR SHALL PROTECT ALL EXISTING STRUCTURES NOT NOTED FOR DEMOLITION & REMOVAL DURING REMOVALS. ANY DAMAGED STRUCTURES TO REMAIN SHALL BE REPAIRED OR REPLACED AT HIS COST TO THE OWNER.

ALL MATERIALS IDENTIFIED FOR REMOVAL SHALL BE DISPOSED OFF SITE IN ACCORDANCE WITH STATE AND LOCAL LAWS.

PROPOSED FEATURES LEGEND

	CONSTRUCTION LIMITS
	CLEAR AND GRUB TREE (0.21 ACRE)
	REMOVE BITUMINOUS PAVEMENT

REMOVAL NOTES:

- ① REMOVE OR RELOCATE EXISTING SHIPPING CONTAINER
- ② SEAL AND ABANDON EXISTING WELL

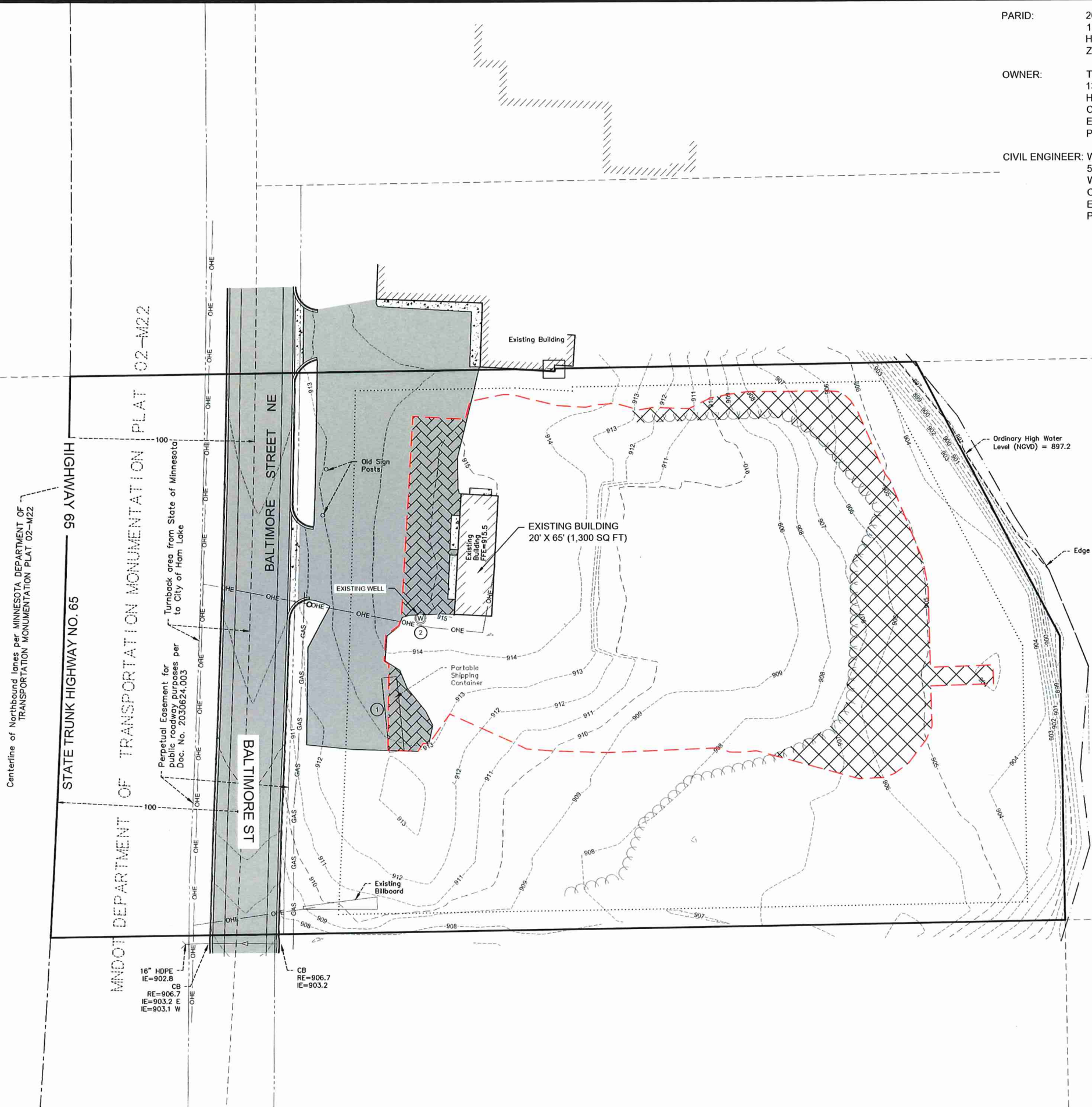

Centerline of Northbound lanes per MINNESOTA DEPARTMENT OF TRANSPORTATION MONUMENTATION PLAT 02-M22

STATE TRUNK HIGHWAY NO. 65

MINN. DEPARTMENT OF TRANSPORTATION MONUMENTATION PLAT 02-M22

BALTIMORE STREET NE

BALTIMORE ST

Perpetual Easement for public roadway purposes per Doc. No. 2030624.003

Turnback area from State of Minnesota to City of Ham Lake

EXISTING WELL

EXISTING BUILDING 20' X 65' (1,300 SQ FT)

Existing Building

Old Sign Posts

Portable Shipping Container

Existing Billboard

Ordinary High Water Level (NGVD) = 897.2

Edge of wet land

16" HDPE
IE=902.8
CB
RE=906.7
IE=903.2
IE=903.1 W

CB
RE=906.7
IE=903.2



ALL UNDERGROUND AND OVERHEAD UTILITY LOCATIONS SHOWN ARE APPROXIMATE. THERE MAY BE ADDITIONAL UNDERGROUND AND OVERHEAD UTILITIES NOT SHOWN ON THE PLAN THAT MAY BE REQUIRED TO BE REMOVED. IT IS THE CONTRACTORS RESPONSIBILITY TO REQUEST A GOPHER STATE ONE CALL PRIOR TO THE START OF ANY CONSTRUCTION AND COORDINATE ALL WORK WITH THE RESPECTIVE UTILITY COMPANIES.

DRAFT - NOT FOR CONSTRUCTION



I HEREBY CERTIFY THAT THIS PLAN, SPECIFICATION, OR REPORT WAS PREPARED BY ME OR UNDER MY CLOSE PERSONAL SUPERVISION AND THAT I AM A duly licensed PROFESSIONAL ENGINEER UNDER THE LAWS OF THE STATE OF MINNESOTA.

FRANK E. BRODEEN
 DATE: 8/8/2023 LIC. NO. 97780

DATE	REVISION DESCRIPTION	BY
AUGUST 2023 <td>AS SHOWN <td></td> </td>	AS SHOWN <td></td>	
FEB		
TMR		

JOB NUMBER: 2023-10749
 DRAWN BY: AS SHOWN
 CHECKED BY: TMR

15555 BALTIMORE ST NE - PROPOSED BUILDING EXPANSION
 HAM LAKE, MN
 ANOKA COUNTY
 EXISTING CONDITIONS AND REMOVALS PLAN

EXISTING PROPERTY DESCRIPTION: (per Warranty Deed Doc. No. 2377642.001)

The North 300.00 feet of that part of Government Lot 2, Section 20, Township 32, Range 23, Anoka County, Minnesota, lying South of a line commencing on the West line of said Government Lot 2 at a point 680.00 feet South of the Northwest corner thereof; thence easterly and parallel with the North line of said Government Lot 2 to the East line thereof, and East of a line beginning at a point on the South line of said Section 20, distant 100 feet easterly of the South Quarter corner thereof; thence run northerly at an angle of 89 degrees 18 minutes with said South section line (measured from East to North) for 248.5 feet; thence deflect to the right at an angle of 7 degrees 11 minutes for 3,629.9 feet; thence deflect to the left on a 0 degree 45 minute curve (delta angle 13 degrees 33 minutes 30 seconds) for 1,807.7 feet and there terminating; subject to public highway

Excepting therefrom the following described property:

Commencing at a point on the West line of said Government Lot 2 distant 680.00 feet southerly of the Northwest corner thereof; thence North 88 degrees 39 minutes 15 seconds East, assumed bearing, parallel with the North line of said Government Lot 2 a distance of 817.73 feet to the point of beginning of the land to be described; thence continue North 88 degrees 39 minutes 15 seconds East a distance of 21.26 feet; thence South 2 degrees 09 minutes 41 seconds West a distance of 1.50 feet; thence North 87 degrees 18 minutes 02 seconds West a distance of 21.22 feet to the point of beginning.

Which lies Westerly of the following described line:

Commencing on the west line of said Government Lot 2, at a point 680.00 feet south of the northwest corner of said Government Lot 2; thence North 89 degrees 09 minutes 35 seconds East (assumed bearing) on a line parallel with the north line of said Government Lot 2 a distance of 1033.74 feet to the point of beginning of the line to be described; thence South 27 degrees 32 minutes 01 seconds East 166.05 feet; thence South 00 degrees 50 minutes 09 seconds East 252.24 feet; thence South 38 degrees 25 minutes 17 seconds East 181.81 feet; thence South 53 degrees 39 minutes 03 seconds East 86.55 feet; thence South 00 degrees 50 minutes 09 seconds East 64.32 feet to the south line of said Government Lot 2 and said line there terminating.

PARKING CALCULATIONS:

PROFESSIONAL OFFICE SPACE REQUIREMENTS:

1 SPACE FOR EACH 205 SQ FT OF FLOOR AREA.

MIN. SPACES REQUIRED = 1 (1,297 SQFT / 250 SQ FT) = 5.2 SPACES = 6 SPACES MIN.

WAREHOUSE REQUIREMENTS:

1 SPACE FOR EACH 2,000 SQ FT OF FLOOR AREA OR 1 SPACE FOR EACH EMPLOYEE ON MAXIMUM WORKING SHIFT.

MIN. SPACES REQUIRED = 1 (8,400 SQFT / 2,000 SQ FT) = 4.2 SPACES = 5 SPACES MIN.

EMPLOYEES ON-SITE DURING MAXIMUM WORKING SHIFT = 5 EMPLOYEES

TOTAL SPACES REQUIRED = 6 SPACES + 5 SPACES + 1 ACCESSIBLE SPACE = 12 SPACES

TOTAL SPACES PROVIDED: 19 SPACES + 1 ACCESSIBLE SPACE = 20 SPACES

POTENTIAL FUTURE PARKING SPACES = 7 SPACES

(XX) TOTAL NUMBER OF SPACES IN EACH PARKING AREA

PARID: 20-32-23-12-0025
15555 BALTIMORE STREET NE
HAM LAKE, MINNESOTA 55304
ZONE: COMMERCIAL - TIER 1 (CD-1)

OWNER: TOUCHDOWN AND RICHARDS LLC
13837 LINCOLN ST NE
HAM LAKE, MN 55304
CONTACT: ERIK GRAMS
EMAIL: ERIK@TOUCHDOWNTILE.COM
PH: (612)-747-3605

CIVIL ENGINEER: WIDSETH (WIDSETH SMITH NOLTING)
5368 266TH ST
WYOMING, MN 55092
CONTACT: FRANK BRODEEN, PE
EMAIL: FRANK.BRODEEN@WIDSETH.COM
PH: (651)-358-2345

LAND USE CALCULATIONS:

TOTAL PROJECT DISTURBED AREA = 1.07 ACRES

TOTAL PROPERTY AREA (INCLUDING ROAD ROW) = 3.57 ACRES

NET TOTAL PROPERTY (NOT INCLUDING ROAD ROW) = 2.72 ACRES

EXISTING NET IMPERVIOUS COVERAGE = 0.36 ACRES

EXISTING NET IMPERVIOUS COVERAGE = 13%

PROPOSED NET IMPERVIOUS COVERAGE = 0.68 ACRES

PROPOSED NET IMPERVIOUS COVERAGE = 25%

PROPOSED GREEN SPACE = 75%

SITE PLAN NOTES:

THE SUBSURFACE UTILITY INFORMATION IN THIS PLAN IS UTILITY QUALITY LEVEL D. THIS QUALITY LEVEL WAS DETERMINED ACCORDING TO THE GUIDELINES OF CIASCE 38-2, ENTITLED 'STANDARD GUIDELINES FOR THE COLLECTION AND DEPICTION OF EXISTING SUBSURFACE UTILITY DATA'

CONTRACTOR SHALL BE RESPONSIBLE FOR PROVIDING AND MAINTAINING TRAFFIC CONTROL AND SHALL BE IN COMPLIANCE WITH THE MINNESOTA UNIFORM TRAFFIC CONTROL DEVICES MANUAL AND TEMPORARY TRAFFIC CONTROL ZONE LAYOUTS FIELD MANUAL. THE TRAFFIC CONTROL SHALL BE APPROVED BY THE CITY PRIOR TO INSTALLATION.

THE CONTRACTOR SHALL VERIFY ALL EXISTING CONDITIONS PRIOR TO CONSTRUCTION AND NOTIFY OWNER AND ENGINEER OF ANY DIFFERENCES BETWEEN THE FIELD AND THE PLAN.

THE CONTRACTOR SHALL RECEIVE THE NECESSARY PERMITS/PERMITS FOR ALL WORK LOCATED OUTSIDE OF THE MUNICIPAL RIGHT OF WAY AND PROPERTY LIMITS.

SEE CIVIL DETAILS SHEET FOR PROPOSED GRAVEL SURFACE SECTION INFORMATION.

PROPOSED FEATURES LEGEND

	CONSTRUCTION LIMITS
	PROPOSED BITUMINOUS SURFACE (SEE DETAILS FOR TYPICAL SECTION)
	PROPOSED CONCRETE SURFACE (SEE DETAILS FOR TYPICAL SECTION)

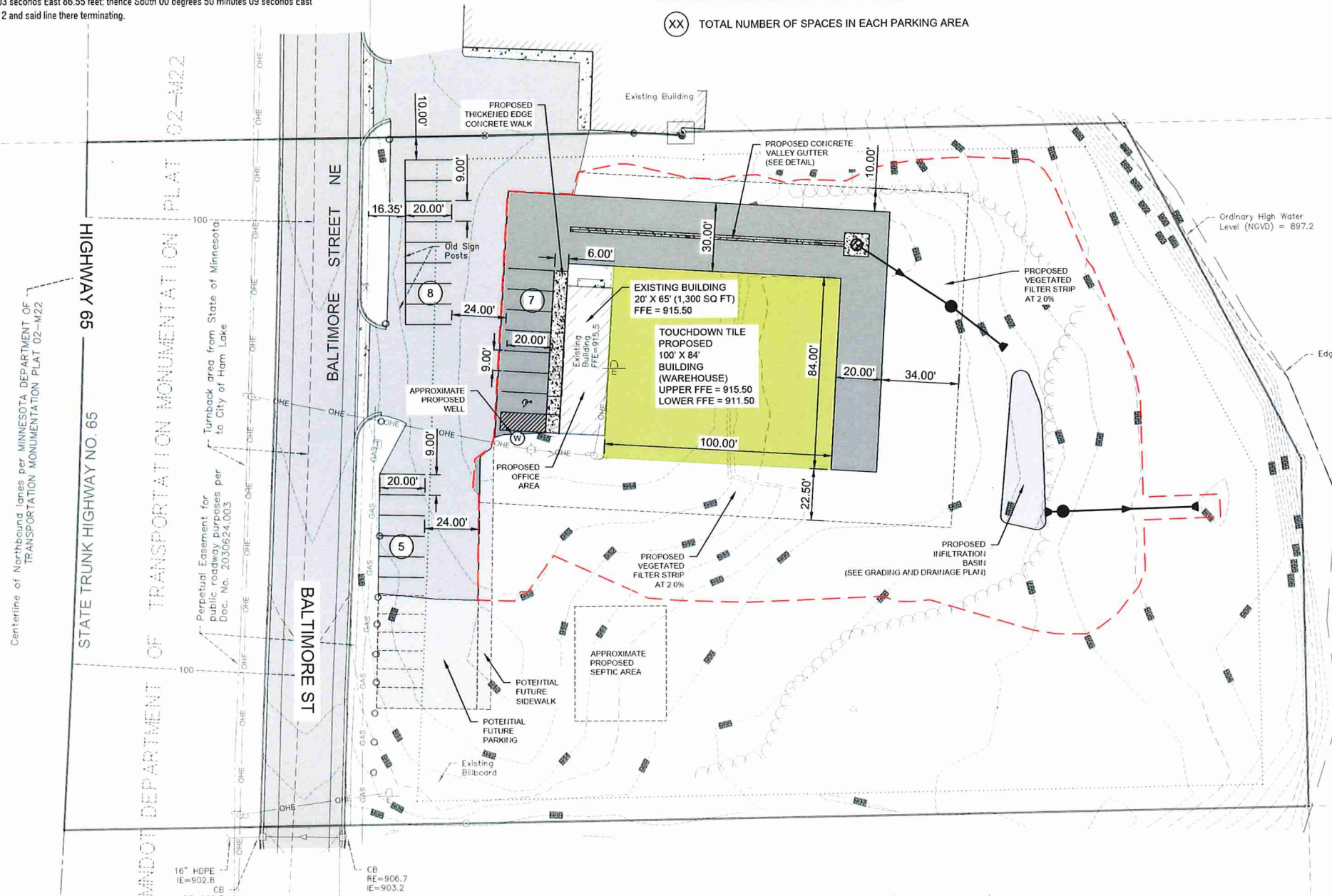

CAUTION ALL UNDERGROUND AND OVERHEAD UTILITY LOCATIONS SHOWN ARE APPROXIMATE. THERE MAY BE ADDITIONAL UNDERGROUND AND OVERHEAD UTILITIES NOT SHOWN ON THE PLAN THAT MAY BE REQUIRED TO BE REMOVED. IT IS THE CONTRACTORS RESPONSIBILITY TO REQUEST A GOPHER STATE ONE CALL PRIOR TO THE START OF ANY CONSTRUCTION AND COORDINATE ALL WORK WITH THE RESPECTIVE UTILITY COMPANIES.

DRAFT - NOT FOR CONSTRUCTION

WIDSETH ARCHITECTS • ENGINEERS • SCIENTISTS • SURVEYORS

MEMBER COMPANY OF THE NATIONAL ASSOCIATION OF ARCHITECTS, THE NATIONAL ASSOCIATION OF ENGINEERS, THE NATIONAL ASSOCIATION OF SCIENTISTS AND SURVEYORS, AND THE NATIONAL ASSOCIATION OF PROFESSIONAL ENGINEERS AND SURVEYORS. I AM A DULY LICENSED PROFESSIONAL ENGINEER UNDER THE LAWS OF THE STATE OF MINNESOTA.

DATE: 8/01/2023 LIC. NO. 57789
FRANK E. BRODEEN

DATE	REVISION DESCRIPTION

DATE: AUGUST 2023 AS SHOWN
SCALE: AS SHOWN
DRAWN BY: FEB
CHECKED BY: TMH
JOB NUMBER: 2023-10749

15555 BALTIMORE ST NE - PROPOSED BUILDING EXPANSION
HAM LAKE, MN
ANOKA COUNTY
SHEET NO. **C5.0**
SHEET 6 OF 10

PARID: 20-32-23-12-0025
 15555 BALTIMORE STREET NE
 HAM LAKE, MINNESOTA 55304
 ZONE: COMMERCIAL - TIER 1 (CD-1)

OWNER: TOUCHDOWN AND RICHARDS LLC
 13837 LINCOLN ST NE
 HAM LAKE, MN 55304
 CONTACT: ERIK GRAMS
 EMAIL: ERIK@TOUCHDOWN TILE.COM
 PH: (612)-747-3605

CIVIL ENGINEER: WIDSETH (WIDSETH SMITH NOLTING)
 5368 266TH ST
 WYOMING, MN 55092
 CONTACT: FRANK BRODEEN, PE
 EMAIL: FRANK.BRODEEN@WIDSETH.COM
 PH: (651)-358-2345

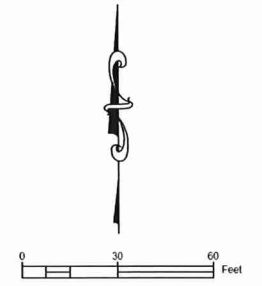

GENERAL CONSTRUCTION NOTES:

THE CONTRACTOR SHALL VERIFY ALL EXISTING CONDITIONS PRIOR TO CONSTRUCTION AND NOTIFY OWNER OF ANY DIFFERENCES BETWEEN THE FIELD AND PLAN.

UNLESS OTHERWISE NOTED, ALL MATERIALS, CONSTRUCTION TECHNIQUES AND TESTING SHALL CONFORM TO THE "STANDARD SPECIFICATIONS FOR CONSTRUCTION" AS PUBLISHED BY THE MINNESOTA DEPARTMENT OF TRANSPORTATION, 2020 EDITION. THE CONTRACTOR SHALL REQUIRE ALL PROCEDURES AS OUTLINED BY THE LOCAL AGENCY.

THE CONTRACTOR SHALL RECEIVE THE NECESSARY PERMISSIONS/PERMITS FOR ALL WORK LOCATED OUTSIDE OF THE MUNICIPAL RIGHT-OF-WAY AND PROPERTY LIMITS.

THE CONTRACTOR SHALL VERIFY ALL EXISTING ELEVATIONS PRIOR TO BEGINNING CONSTRUCTION.

TURF ESTABLISHMENT AND EROSION CONTROL PLAN NOTES:

THE SUBSURFACE UTILITY INFORMATION IN THIS PLAN IS UTILITY QUALITY LEVEL D. THIS QUALITY LEVEL WAS DETERMINED ACCORDING TO THE GUIDELINES OF CHASCE 38-2, ENTITLED "STANDARD GUIDELINES FOR THE COLLECTION AND DEPICTION OF EXISTING SUBSURFACE UTILITY DATA".

ALL CONSTRUCTION SHALL CONFORM TO LOCAL, STATE, AND FEDERAL REGULATIONS INCLUDING THE NATIONAL POLLUTANT DISCHARGE ELIMINATION SYSTEM (NPDES) PERMIT REQUIREMENTS.

ALL SILT FENCE AND SEDIMENT CONTROL MEASURES SHALL BE IN PLACE PRIOR TO ANY EXCAVATION/CONSTRUCTION AND SHALL BE MAINTAINED UNTIL VIABLE TURF OR GROUND COVER HAS BEEN ESTABLISHED. MAINTENANCE AND REMOVAL OF SEDIMENT CONTROL DEVICES SHALL BE INCIDENTAL TO THE GRADING CONTRACT.

ALL STREETS UTILIZED FOR PROJECT CONSTRUCTION MUST BE CLEANED AT THE END OF EACH DAY. A ROCK ENTRANCE TO THE SITE MUST BE PROVIDED ACCORDING TO REDUCE TRACKING OF SEDIMENT ONTO PUBLIC STREETS.

ALL EXPOSED SOILS MUST BE STABILIZED WITHIN 7 CALENDAR DAYS OF ROUGH GRADE COMPLETION OR AFTER CONSTRUCTION TERMINATES. ALL STOCKPILES SHALL HAVE ADEQUATE SEDIMENT TRAPPING SYSTEMS INSTALLED AROUND THEM.

ALL AREAS TO BE ESTABLISHED TO GRASS COVER SHALL RECEIVE 4" OF TOPSOIL AND SOD OR SEED. THESE AREAS SHALL BE WATERED UNTIL A HEALTHY STAND OF GRASS IS OBTAINED.

SEE PLAN FOR A COMPLETE LEGEND OF HATCHES AND SYMBOLS USED FOR TURF ESTABLISHMENT AND EROSION CONTROL.

LEGEND:

- ***** SILT FENCE
- BIO-○-BIO-○-BIO-○ SEDIMENT CONTROL LOG (BIOROLL)
- SEED MIXTURE 25-131 @ 220 LBS/ACRE
FERTILIZER TYPE 3 @ 350 LBS/ACRE
REFF CATEGORY 25
- SEED MIXTURE 33-261 @ 35 LBS/ACRE
FERTILIZER TYPE 3 @ 200 LBS/ACRE
REFF CATEGORY 10
- ROCK CONSTRUCTION EXIT
- RANDOM RIP RAP CL II
- STORM DRAIN INLET PROTECTION/CULVERT END CONTROL

CONSTRUCTION NOTES:

- ① INSTALL BIOROLL PRIOR TO INFILTRATION BASIN CONSTRUCTION AND AFTER STABILIZATION OF CONTRIBUTING DRAINAGE AREA.

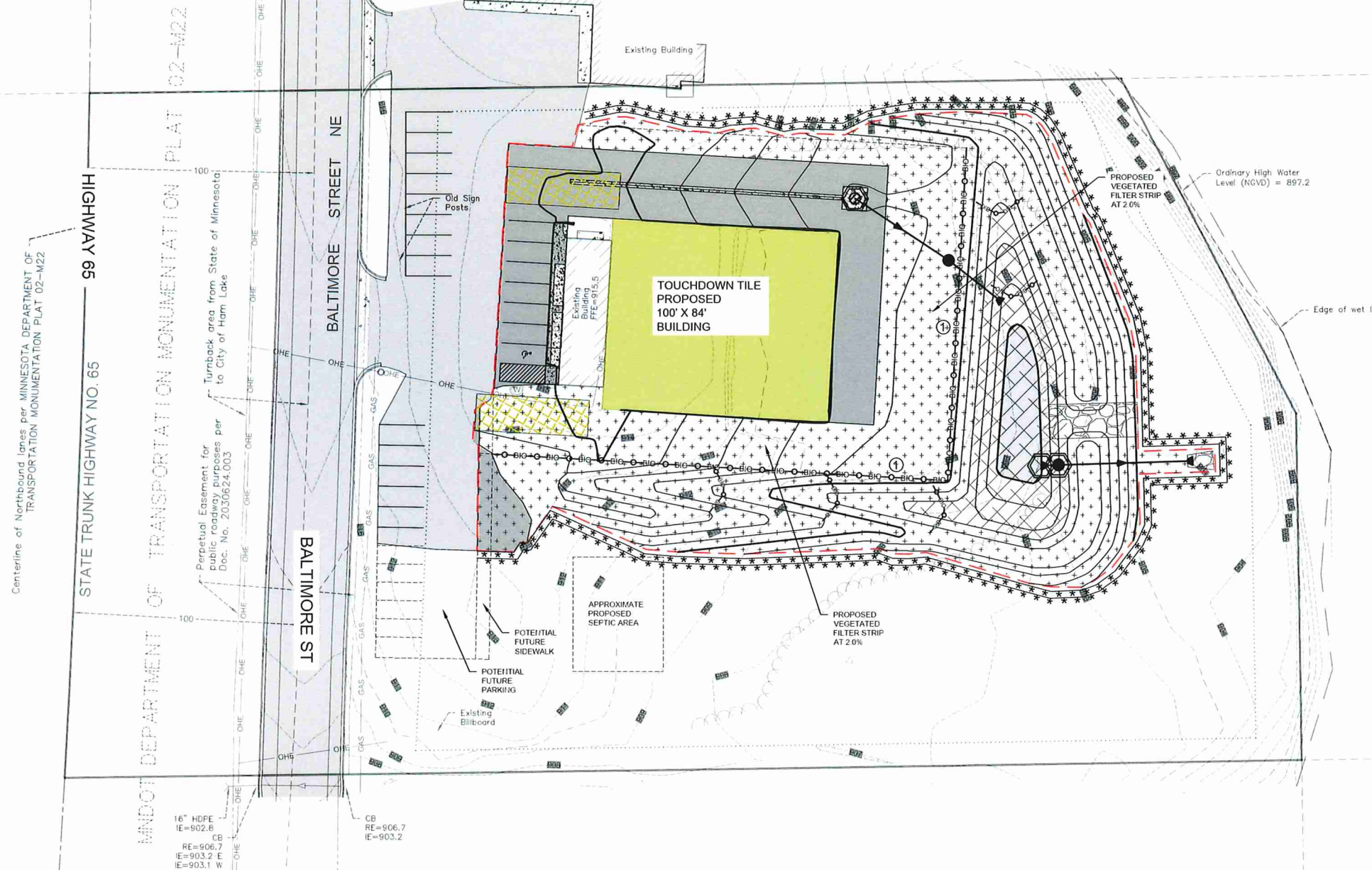

Centerline of Northbound lanes per MINNESOTA DEPARTMENT OF TRANSPORTATION MONUMENTATION PLAT 02-M22

STATE TRUNK HIGHWAY NO. 65

MINNESOTA DEPARTMENT OF TRANSPORTATION MONUMENTATION PLAT 02-M22

Perpetual Easement for public roadway purposes per Doc. No. 2030624.003 to City of Ham Lake

BALTIMORE ST

BALTIMORE STREET NE

16" HDPE
IE=902.8
CB
RE=906.7
IE=903.2
IE=903.1

CB
RE=906.7
IE=903.2

Existing Building

Old Sign Posts

TOUCHDOWN TILE PROPOSED 100' X 84' BUILDING

Existing Building FFE=915.5

POTENTIAL FUTURE SIDEWALK

POTENTIAL FUTURE PARKING

Existing Billboard

APPROXIMATE PROPOSED SEPTIC AREA

PROPOSED VEGETATED FILTER STRIP AT 2.0%

PROPOSED VEGETATED FILTER STRIP AT 2.0%

Ordinary High Water Level (NGVD) = 897.2

Edge of wet land



ALL UNDERGROUND AND OVERHEAD UTILITY LOCATIONS SHOWN ARE APPROXIMATE. THERE MAY BE ADDITIONAL UNDERGROUND AND OVERHEAD UTILITIES NOT SHOWN ON THE PLAN THAT MAY BE REQUIRED TO BE REMOVED. IT IS THE CONTRACTORS RESPONSIBILITY TO REQUEST A GOPHER STATE ONE CALL PRIOR TO THE START OF ANY CONSTRUCTION AND COORDINATE ALL WORK WITH THE RESPECTIVE UTILITY COMPANIES.

DRAFT - NOT FOR CONSTRUCTION



HEREBY CERTIFY THAT THIS PLAN, SPECIFICATION OR REPORT WAS PREPARED BY ME OR UNDER MY CLOSE PERSONAL SUPERVISION AND THAT I AM A DULY LICENSED PROFESSIONAL ENGINEER UNDER THE LAWS OF THE STATE OF MINNESOTA

FRANK E. BRODEEN DATE: 8/02/23 LIC. NO. 5730

DATE	REVISION DESCRIPTION
AUGUST 2023 AS SHOWN	
FEB	
TUH	

DATE: AUGUST 2023 AS SHOWN
 SCALE: DRAWN BY: FEB
 CHECKED BY: TUH
 JOB NUMBER: 2023-10749

15555 BALTIMORE ST NE - PROPOSED BUILDING EXPANSION
 HAM LAKE, MN
 ANOKA COUNTY
 TURF ESTABLISHMENT AND EROSION CONTROL PLAN

SHEET NO. C7.0
 SHEET 8 OF 10

Applicant:
Touchdown Tile LLC

Project Name:
15555 Baltimore Street NE Building Expansion Project

Application date:
To Be Determined (TBD) and will be documented in this Stormwater Pollution Prevention Plan (SWPPP) narrative prior to the start of construction.

Nature of construction activity description:
The project will consist of construction of an 84' x 100' building addition onto an existing building on the property. Site grading will take place to facilitate the building construction, as well as aggregate surface around the proposed building for access and parking. An infiltration basin will be constructed to treat stormwater runoff, with established vegetated filter strips for pretreatment. Runoff from the north side of the proposed building addition will flow to a proposed drop inlet with a proposed 4' sump. A secondary manhole will be constructed with another sump for pretreatment as well.

The proposed site consists of one soil type.
Zimmerman fine sand, 1 to 6 percent slopes

The project is anticipated to begin in Summer/Fall 2023, with construction scheduled to be complete in Fall 2023.

Total estimated area to be disturbed by the project is: 1.2 AC

Name of person with Best Management Practices (BMP's) experience who will oversee SWPPP implementation and coordinate with contractor:
TBD and will be documented in this SWPPP narrative prior to start of construction.

Person, organization, or entity responsible for long term maintenance of permanent stormwater treatment system:
TBD and will be documented in this SWPPP narrative prior to start of construction.

Documentation of all trained individuals:

SWPPP preparer:
Company: Widseth
Name: Ella Kohls
Address: 5368 266th Street
City, State Zip: Wyoming, MN 55092
Email: Ella.Kohls@widseth.com
Phone: 651-358-2351
Training organization/sponsor:
Training date(s):
Training activity/content: Design of Construction SWPPP
Instructor(s) name(s):

Individual overseeing implementation, revision and/or amendment the SWPPP that are available for an onsite inspection within 72 hours upon request of MPCA: TBD and will be documented in this SWPPP narrative prior to start of construction.

Company: _____
Name: _____
Address: _____
City, State Zip: _____
Email: _____
Phone: _____
Training organization/sponsor: _____
Training date(s): _____
Training activity/content: _____
Instructor(s) name(s): _____

Individual overseeing implementation, revision and/or amendment the SWPPP: TBD and will be documented in this SWPPP narrative prior to start of construction.

Company: _____
Name: _____
Address: _____
City, State Zip: _____
Email: _____
Phone: _____
Training organization/sponsor: _____
Training date(s): _____
Training activity/content: _____
Instructor(s) name(s): _____

Individual performing or supervising the installation, maintenance and repair of BMP's: TBD and will be documented in this SWPPP narrative prior to start of construction.

Company: _____
Name: _____
Address: _____
City, State Zip: _____
Email: _____
Phone: _____
Training organization/sponsor: _____
Training date(s): _____
Training activity/content: _____
Instructor(s) name(s): _____

Installation Timing of Erosion Prevention and Sediment Control BMP's:

Erosion and sediment control BMP's must be installed as necessary to minimize erosion from disturbed surfaces and capture sediment onsite. All BMP's must conform to 2018 MNR100001 Permit 2018 sections 7, 8 and 9.

Temporary erosion control BMP's.

The General Contractor is responsible for the Erosion Prevention Practices contained in 2018 MNR100001 Permit 2018 section 8. The General Contractor must plan for and implement appropriate construction phasing, vegetative buffer strips, horizontal slope grading and other construction practices that minimize erosion. The location of areas not to be disturbed must be delineated (marked) on the development site before work begins.

Examples of Temporary Erosion Control BMP's

- Poly Cover Stockpile or Slope
- Construction Phasing
 - Phasing must be implemented to ensure that more area than can be effectively inspected and maintained in accordance with the MNR100001 permit is not disturbed.
- Disc Anchored Straw
 - Minnesota Department of Transportation (MnDOT) reference:
 - Disc anchoring must be performed as necessary and/or according to the plan included in this SWPPP.
 - Disc anchor Type 1, Type 3, or Type 8 mulches with a disk anchoring tool as required by the contract immediately after placement unless otherwise approved by the Engineer.
 - Disc anchoring must be installed as per MnDOT spec. 2575.3.D.
- Rolled Erosion Control Products
 - The contractor must minimize the need for disturbance of portions of the project that have steep slopes (3:1 or steeper). For steep sloped areas that must be disturbed, the contractor must use techniques such as phasing, and stabilization practices designed for steep slopes including draining and terracing. Slopes steeper than 3:1 must be protected by rolled erosion prevention products.
 - MnDOT reference:
 - Rolled erosion control products must be placed in the areas as shown on the plan included in this SWPPP.
 - Rolled erosion control products must be Rolled Erosion Prevention Products, Turf Reinforcement Mats, or Winter Blankets, according to plan. Materials must meet the requirements of MnDOT spec. 3885.
 - Rolled erosion control products must be placed as per MnDOT spec. 2575.3.G.

- Wood Chips
- Vegetation
 - MnDOT reference:
 - Protect and preserve vegetation per the requirements of MnDOT spec. 2572.3.A.
 - Before work begins, permittees must delineate the location of areas not to be disturbed.
- Mulch
 - All disturbed soil areas must be temporarily mulched with Rapid Stabilization, Method 3, initiated immediately, when the area will not actively be worked for 7/14 days.
 - MnDOT reference:
 - Mulch must be placed in the areas as shown on the plan included in this SWPPP.
 - Mulch must be Temporary, Type 1, Type 3, Type 4, Type 5, Type 6, Type 7, Type 8, Type 9, Winter, or Hydraulic Mulch according to plan. Materials must meet the requirements of MnDOT spec. 3882 or MnDOT spec. 3884.
 - Mulch must be applied as per MnDOT spec. 2575.3.C or MnDOT spec. 3575.3.E.
- Temporary Sediment Control BMP's
 - The General Contractor is responsible for the Sediment Control Practices contained in MNR100001 Permit 2018 reference 9 of the NPDES Permit. Sediment Control Practices must be installed on all down gradient perimeters before any upgradient land disturbing activities begin. These practices must remain in place until Permit Termination Conditions have been established in accordance with MNR100001 Permit 2018 reference 13 of the NPDES Permit.
- Examples of Temporary Sediment Control BMP's
 - Floating Silt Curtain
 - MnDOT reference:
 - Flotation silt curtain must be placed in the areas as shown on the plan included in this SWPPP.
 - Flotation silt curtain must be light duty or heavy duty and meet the requirements of MnDOT spec. 3887.
 - Flotation silt curtain must be installed as per MnDOT spec. 2573.3.I.
 - Silt Fence
 - MnDOT reference:
 - Silt fence must be placed in the areas as shown on the plan included in this SWPPP.
 - Silt fence must be preassembled, machine sliced, hand installed, super duty, or turbidity barrier type, according to plan. Materials must meet the requirements of MnDOT spec. 3886.
 - Silt fence must be installed as per MnDOT spec. 2573.3.B.
 - Sediment Control Logs
 - MnDOT reference:
 - Sediment control logs must be placed in the areas as shown on the plan included in this SWPPP.
 - Sediment control logs must be Type Straw, Wood Fiber, Coir, Wood Chip, Compost, Rock, or Wood Fiber and Blanket Systems and meet the requirements of MnDOT spec. 3897.
 - Sediment control logs must be installed as per MnDOT spec. 2573.3.F.
 - Filter Berms
 - Silt fence or windrowed topsoil will be used as the primary control. Sediment control logs will be used as secondary control along each side of roadway at all low points and areas of high velocity drainage to prevent sediment from draining off roadway.
 - MnDOT reference:
 - Filter berms must be placed in the areas as shown on the plan included in this SWPPP.
 - Filter berms must be Type 1, 2, 3, 4, or 5. Materials must meet the requirements of MnDOT spec. 3874.
 - Filter berms must be installed as per MnDOT spec. 2573.3.E.
 - Bale Barriers
 - MnDOT reference:
 - Bale Barriers must be placed in the areas as shown on the plan included in this SWPPP.
 - Bale Barriers must be installed as per MnDOT spec. 2573.3.C.
 - Rock Ditch Check
 - Sediment Control Log Ditch Check
 - Filter Bag Insert Inlet Protection
 - Rock / Compost Log Inlet Protection
 - Tube Riser Inlet Protection
 - Pop-Up Head Inlet Protection
 - Inlet Hat Inlet Protection
 - Silt Fence Ring and Rock Filter Berm Inlet Protection
 - Sandbag Barriers
 - MnDOT reference:
 - Sandbag barriers must be placed in the areas as shown on the plan included in this SWPPP.
 - Sandbag Barriers must be installed as per MnDOT spec. 2573.3.D.
 - Slash Mulch, Crushed Rock, or Sheet Pad Construction Exit
 - Rock construction exits must be placed at all locations construction vehicles will be exiting the project area. If the contractor chooses to access the site from locations other than where temporary rock construction exits are shown on the plan, additional construction exit controls must be placed at these locations as well. If sediment tracking is discovered on adjacent streets, the sediment must be removed with a street sweeper or other approved method within one calendar day of discovery. This must be done throughout the duration of the project. The sediment may be returned to the exposed areas of the site or disposed of offsite per MPCA requirements.
 - MnDOT reference:
 - Construction exit controls must be placed in the areas as shown on the plan included in this SWPPP.
 - Construction exit controls must be constructed with slash mulch, crushed rock, temporary paving, reinforced geotextile, sheet pads, floating road, timber pad, or rumble pad.
 - Construction exit controls must be installed as per MnDOT spec. 2573.3.K.
 - Rumble Pad Construction Exit
 - Culvert End Controls
 - MnDOT reference:
 - Culvert end controls must be placed in the areas as shown on the plan included in this SWPPP.
 - Culvert End Controls must be installed as per MnDOT spec. 2573.3.L.
 - Culvert Standpipe Inlet Protection
 - Storm Drain Inlet Protection
 - MnDOT reference:
 - Storm drain inlet protection must be placed in the areas as shown on the plan included in this SWPPP.
 - Storm Drain Inlet Protection must be installed as per MnDOT spec. 2573.3.M.
 - Sediment Control Log Weir Culvert Inlet Protection
 - Wood Plank Weir Culvert Inlet Protection
 - Geotextile Fabric Culvert Inlet Protection
 - Geotextile Fabric Culvert Inlet Protection must be placed in the areas as shown on the plan included in this SWPPP.
 - Geotextile Fabric Culvert Inlet Protection must meet requirements of MnDOT spec. 3886.
 - Geotextile Fabric Culvert Inlet Protection
 - a). Culvert inlet protection must be provided at all culvert inlet locations immediately after construction of the culvert. See plan included in this SWPPP for culvert inlet locations.
 - b). Culvert inlet protection must consist of geotextile fabric wrapped around, and completely covering the inlet end section. The geotextile fabric must be the same fabric used in silt fence applications and meet the requirements of MNDOT Spec. 3886.
 - c). The culvert inlet protection must remain in place and adequately maintained until Permit Termination Conditions have been established.
 - d). Culvert inlet protection must be repaired or replaced if damaged during, or after, rain events, or if accumulated sediment reaches 1/2 of the diameter of the culvert pipe. Repair or replacement of culvert inlet protection must be completed within 24 hours of discovery.
 - Temporary Sediment Basins
 - Contractor may construct temporary sedimentation basins in accordance with MNR100001 Permit 2018 reference 14 of the NPDES Permit.
 - Temporary Diversion Ditch
 - Measures must be taken to ensure that "clean" runoff from off site is diverted around disturbed areas on site. Care should be taken that re-routing off site runoff does not result in flooding or other issues on adjacent properties.

Permanent Erosion Cover Methods for all exposed soil areas:

- Concrete
- Bituminous
- Perennial cover
 - Permanent erosion control will be achieved with a density of 70% of the native background vegetation by using sod on all disturbed construction areas.

Stormwater Mitigation Measures proposed as part of environmental, endangered species, archaeological or other required local, state or federal reviews conducted by the project.

No local, state, or federal reviews were conducted for the Project that we are aware of.

Discharges to any U.S. EPA approved TMDL for the pollutants/stressors described in MNR100001 Permit 2018 reference item 23.7

DATE	REVISION DESCRIPTION	BY

DATE	SCALE	AS SHOWN	DATE	SCALE	AS SHOWN
AUGUST 2023					

There are no special or impaired waters within one mile of the project site that will receive stormwater runoff.

Permanent Stormwater Treatment System:

A proposed infiltration basin will be constructed that meets the stormwater management requirements for Coon Creek Watershed District.

Procedures to Amend SWPPP:

The General Contractor must amend the SWPPP as necessary to include additional requirements, such as additional or modified BMP's, designed to correct problems or address situations in accordance with MNR100001 Permit 2018 reference 6 of the NPDES Permit.

Amendments to the SWPPP:

1. Date:
2. Date:
3. Date:
4. Date:
5. Date:

Methods to Minimize Soil Compaction and to Preserve Topsoil:

The General Contractor must avoid construction traffic and maintain the existing condition of pervious "green" areas.

Stormwater Control Design:

No permanent stormwater control for this project is anticipated.

Chemical Treatment Systems to Enhance Sedimentation:

No chemical treatment systems to enhance sedimentation are anticipated for this Project. However, if there are, the contractor needs to reference the below permit requirement.

- Flocculants
 - MnDOT reference:
 - > Flocculants must be applied as specified on the plan included in this SWPPP.
 - > Liquid, Stock, or Granular Flocculant must be used and meet requirements of MnDOT spec. 3898.
 - > Flocculants must be installed as per MnDOT spec. 2573.3.N.

Impervious Surfaces pre- and post-construction:

Existing Impervious (Within Project Area Only) =	0.11 AC
Proposed Impervious Area (Within Project Area Only) =	0.43 AC
Increase of Total Impervious Surface Area=	0.32 AC

Infeasibility Documentation Requirements:

No infeasible documentation requirements are anticipated for the Project.

Site Assessments for Groundwater or Soil Contamination:

No site assessment for groundwater or soil contamination was conducted for the Project that we are aware of.

Tabulated Quantities:

Item	Estimated Quantity
Seeding	0.75 ACRE
Rolled Erosion Prevention Product	3,633 SQ YD
Silt Fence, Type MS	1,582 LN FT
Bioroll	478 LN FT

CONSTRUCTION ACTIVITY REQUIREMENTS:

Erosion Prevention Measures

- ❖ Exposed soils (including stockpiles) must have erosion protection/cover initiated immediately and completed within 14 days (or 7 days per Section 23).
- ❖ For DNR Public Waters with "work in waters restrictions" during specified fish spawning time frames, stabilization must be completed for all exposed soil areas within 200 feet of the water's edge, and draining to the water, within 24 hours during the restriction period.
- ❖ The wetted perimeter of the last 200 linear feet of ditches must be stabilized within 24 hours of connecting to a surface water or property line.
- ❖ Temporary or permanent ditches or swales that are being used as a sediment containment system during construction must be stabilized within 24 hours after no longer being used as a sediment containment system.
- ❖ Pipe outlets must have energy dissipation within 24 hours of connecting to a surface water or permanent stormwater treatment system.
- ❖ Mulch, hydro mulch, tackifier, polyacrylamide, or similar erosion prevention practices cannot be used within the normal wetted perimeter of drainage ditches or swale sections with a continuous slope greater than 2%.

Sediment Control Measures

- ❖ Sediment control practices must be established on downgradient perimeters and upgradient of any buffer zones.
- ❖ Sediment control practices must be established at the base of stockpiles on the downgradient perimeter.
- ❖ Stockpiles must be located outside of natural buffers or surface waters, including stormwater conveyances (e.g., curb and gutter systems) unless there is a bypass.
- ❖ Inlet protection BMP's must be installed according to plan.
- ❖ Vehicle tracking BMP's must be established where vehicles are exiting the site to minimize street tracking. Sediment tracked onto a public street must be removed within 24 hours.
- ❖ Topsoil must be preserved unless infeasible.
- ❖ Soil compaction must be minimized.
- ❖ Discharges from BMP's must be directed to vegetated areas, unless infeasible.
- ❖ 50-foot natural buffers must be preserved or (if maintaining buffer is infeasible) redundant sediment controls must be provided when a surface water is located within 50 feet of the project's earth disturbances and drains to the surface water.

Dewatering and Basin Draining:

- ❖ If dewatering is required on the site, there must be a plan in place to prevent nuisance conditions, erosion, and inundation of wetlands.
- ❖ Dewatering related to the construction activity must comply with MNR100001 Permit 2018 reference 10 of the NPDES Permit. Dewatering discharge that may have turbid or sediment laden discharge must be discharged to a temporary or permanent sedimentation basin on the project site whenever possible and BMP's must be implemented to prevent water containing sediment or other pollutants from being discharged to surface waters or downstream properties.
- ❖ If using filters with backwash water, backwash water must be hauled away for disposal, returned to the beginning of the treatment process, or incorporated into the site in a manner that does not erode into runoff.

Inspection Requirements:

- ❖ The SWPPP must identify the trained person (as identified in item 21.2.b) who will conduct inspections.
- ❖ Inspections must be performed once every 7 days.
- ❖ Inspections must be performed within 24 hours of a rain event greater than 0.5 inches in 24 hours.
- ❖ Inspection and Maintenance records should include:

1. Date and time of inspection.
2. Name of person(s) conducting inspections.
3. Accurate findings of inspections, including the specific location where corrective actions are needed.
4. Corrective actions taken (including dates, times, and party completing maintenance activities).
5. Date and amount of rainfall events greater than 0.5 inch in 24 hours.
6. Rainfall amounts must be obtained by a properly maintained rain gauge installed onsite, or by a weather station that is within one mile or by a weather reporting system.
7. Requirements to observe any discharge that may be occurring during the inspection. Discharge should also be described and photographed.

Maintenance Requirements:

- ❖ All nonfunctional BMP's must be repaired, replaced, or supplemented with functional BMP's by the end of the next business day after discovery, or as soon as field conditions allow.
- ❖ Perimeter control devices must be repaired, replaced, or supplemented when nonfunctional or sediment reaches one-half the height of the device.
- ❖ Temporary and permanent sediment basins must be drained, and sediment removed when the depth of sediment collected reaches one-half storage volume.
- ❖ All sediment deposits and deltas must be removed from surface waters (including drainage ways, catch basins, and other drainage systems) and the removal areas restabilized within seven days.
- ❖ Sediment on paved surfaces (e.g., sediment tracked from vehicles) must be removed within one calendar day of discovery.

Pollution Prevention Management Measures:

- ❖ Proper storage, handling, and disposal of construction products, materials, and wastes is required. Hazardous materials and toxic waste (including oil, diesel fuel, gasoline, hydraulic fluids, paint solvents, petroleum-based products, wood preservatives, additives, curing compounds, and acids) must be stored in waterproof containers with secondary containment. Storage and disposal of hazardous waste must be in compliance with MPCA regulations. Runoff containing such material must be collected, removed from the site, treated, and disposed at an approved solid waste or chemical disposal facility. Building products that have the potential to leach pollutants and pesticides, fertilizers, treatment chemicals and landscape materials must be under cover by plastic sheeting or temporary roofs to prevent discharge or protected by similar effective means to prevent contact with stormwater.
- ❖ Address fueling and maintenance of equipment or vehicles and spill prevention and response. Spill cleanup materials must be available on site. Material must include but not limited to brooms, mops, rags, gloves, absorbent material, sand plastic and metal containers. Spills greater than 5 gallons that reach storm water conveyance systems connected to a Water of the State must be immediately reported to the MPCA State Duty Officer.
- ❖ Limit exterior vehicle and equipment washing to a defined area of the site. External washing of trucks and other construction vehicles must be limited to a defined area of the site. Runoff must be contained, and waste properly disposed of.
- ❖ Describe the containment for concrete and other washout wastes. Concrete washout site: all liquid and solid wastes generated by concrete washout operations must be contained in a leak proof containment facility or impermeable liner. The liquid and solid wastes must not contact the ground, and there must not be runoff from the concrete washout operations or areas. Liquid and solid wastes must be disposed of properly and in compliance with the MPCA regulations. A sign must be installed adjacent to each washout facility to inform concrete equipment operators to utilize the proper facilities.
- ❖ Portable toilets must be positioned so that they are secure. Licensed sanitary waste management handler must dispose of sanitary waste.

Permit Termination Conditions:

- ❖ Permanent uniform perennial vegetative cover must be established at minimum 70% density of its expected final growth.
- ❖ The permanent stormwater treatment system is constructed, meets all requirements, and is operating as designed.
- ❖ All temporary synthetic erosion prevention and sediment control BMP's must be removed, and the surrounding area must be restored to as designed.
- ❖ Clean out sediment from conveyance systems and permanent stormwater treatment systems (return to design capacity).
- ❖ For residential sites, install temporary erosion protection and downgradient perimeter control and distribute the MPCA's Homeowner Fact Sheet.
- ❖ Submit a Notice of Termination (NOT) to the MPCA.

Record Retention Requirements:

- ❖ Permittees must keep the SWPPP, including all changes to it, and inspections and maintenance records at the site during normal working hours by permittees who have operational control of that portion of the site. The SWPPP and associated records must be stored and maintained by an employee or representative of the Owner for 3 years after the submission of the NOT. Responsibility for overseeing the records will be transferred to another employee or representative should the current personnel become uninvolved with the project or Owner. These records must include the following:
 - 1) The final SWPPP
 - 2) Any other stormwater related permits required for the project
 - 3) Records of all inspection and maintenance conducted during construction
 - 4) All permanent operation and maintenance agreements that have been implemented, including all right-of-way, contracts, covenants and other binding requirements regarding perpetual maintenance
 - 5) All required calculations for design of the temporary and permanent Stormwater Management Systems.

IMPAIRED WATERS MAP

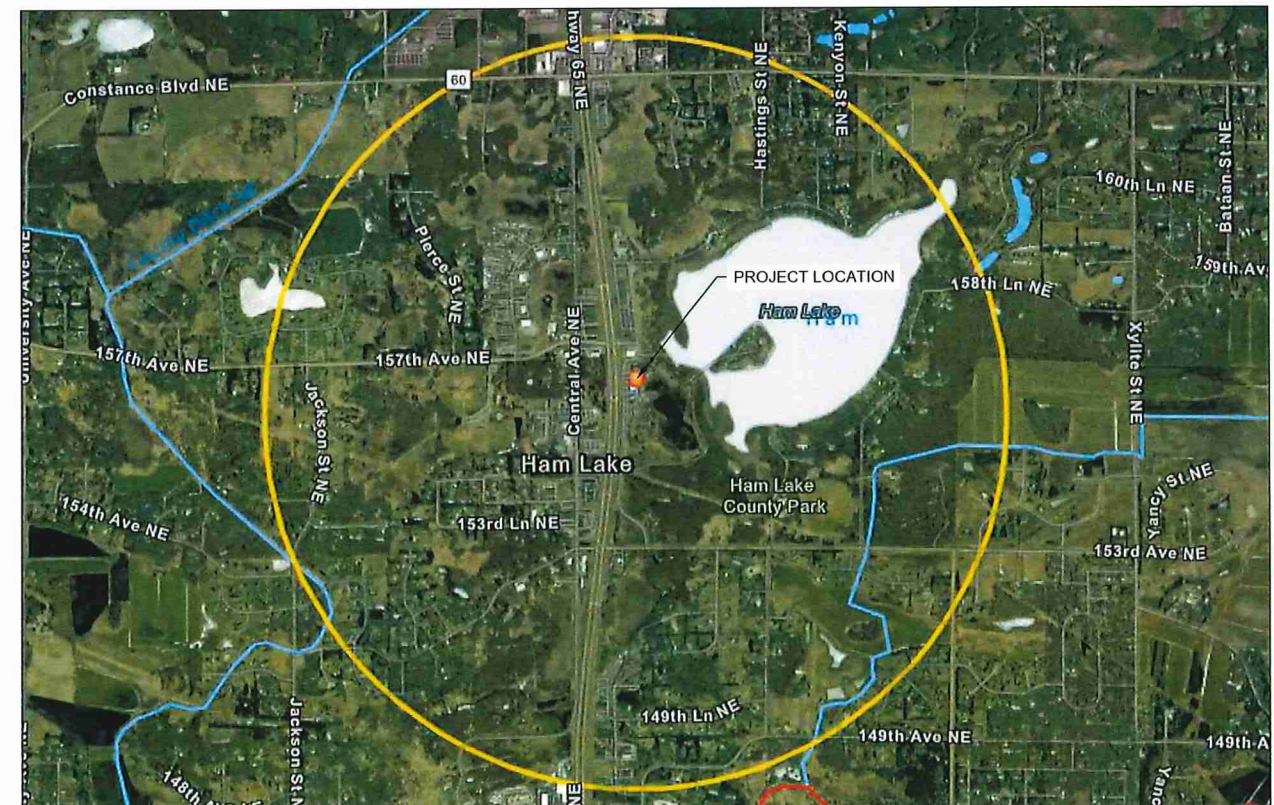

DATE	REVISIONS DESCRIPTION	BY
AUGUST 2023	AS SHOWN	
FEB		

PLANT SCHEDULE				
TREES	BOTANICAL / COMMON NAME	SIZE	CONTAINER	QTY
PS	Populus deltoides monilifera / Plains Cottonwood	1.5" Cal.	B&B	4
QA	Quercus alba / White Oak	2.5" Cal.	B&B	2
ORNAMENTAL TREE	BOTANICAL / COMMON NAME	SIZE	CONTAINER	QTY
AG2	Amelanchier x grandiflora 'Autumn Brilliance' / Autumn Brilliance Apple Serviceberry	1" Cal.	Pot	4
CONIFERS	BOTANICAL / COMMON NAME	SIZE	CONTAINER	QTY
LD	Larix decidua / European Larch	2.5" B&B		5
SHRUBS	BOTANICAL / COMMON NAME	SIZE	CONTAINER	QTY
CR	Cornus sericea / Red Twig Dogwood	#5		7
GFS	Rhus aromatica 'Gro-Low' / Gro-Low Fragrant Sumac	2 gal.	Pot	10
GROUND COVERS	BOTANICAL / COMMON NAME	SIZE	CONTAINER	QTY
	MNDOT - Metro Seed M 33-261 / Stormwater South & West	Hydroseed		19,559 sf

PROPOSED FEATURES LEGEND

	DENOTES CONSTRUCTION LIMITS
	DENOTES PROPOSED BITUMINOUS SURFACE
	DENOTES PROPOSED CONCRETE SURFACE

CONSTRUCTION NOTES:
 ③ PROTECT TREE DURING CONSTRUCTION

PARID: 20-32-23-12-0025
 15555 BALTIMORE STREET NE
 HAM LAKE, MINNESOTA 55304
 ZONE: COMMERCIAL - TIER 1 (CD-1)

OWNER: TOUCHDOWN AND RICHARDS LLC
 13837 LINCOLN ST NE
 HAM LAKE, MN 55304
 CONTACT: ERIK GRAMS
 EMAIL: ERIK@TOUCHDOWN TILE.COM
 PH: (612)-747-3605

CIVIL ENGINEER: WIDSETH (WIDSETH SMITH NOLTING)
 5368 266TH ST
 WYOMING, MN 55092
 CONTACT: FRANK BRODEEN, PE
 EMAIL: FRANK.BRODEEN@WIDSETH.COM
 PH: (651)-358-2345

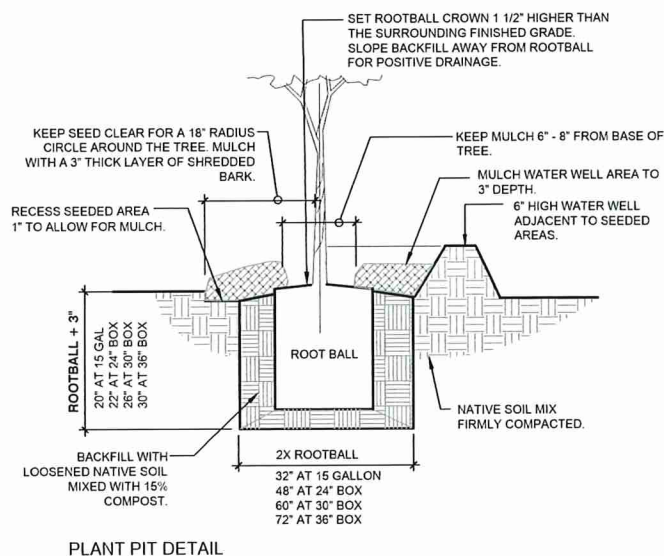
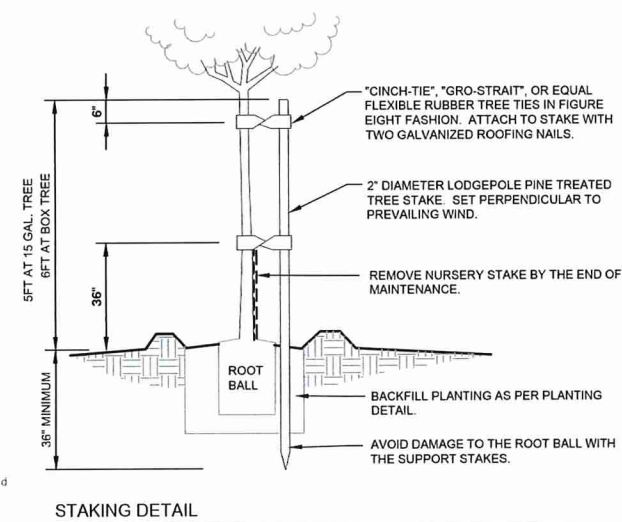
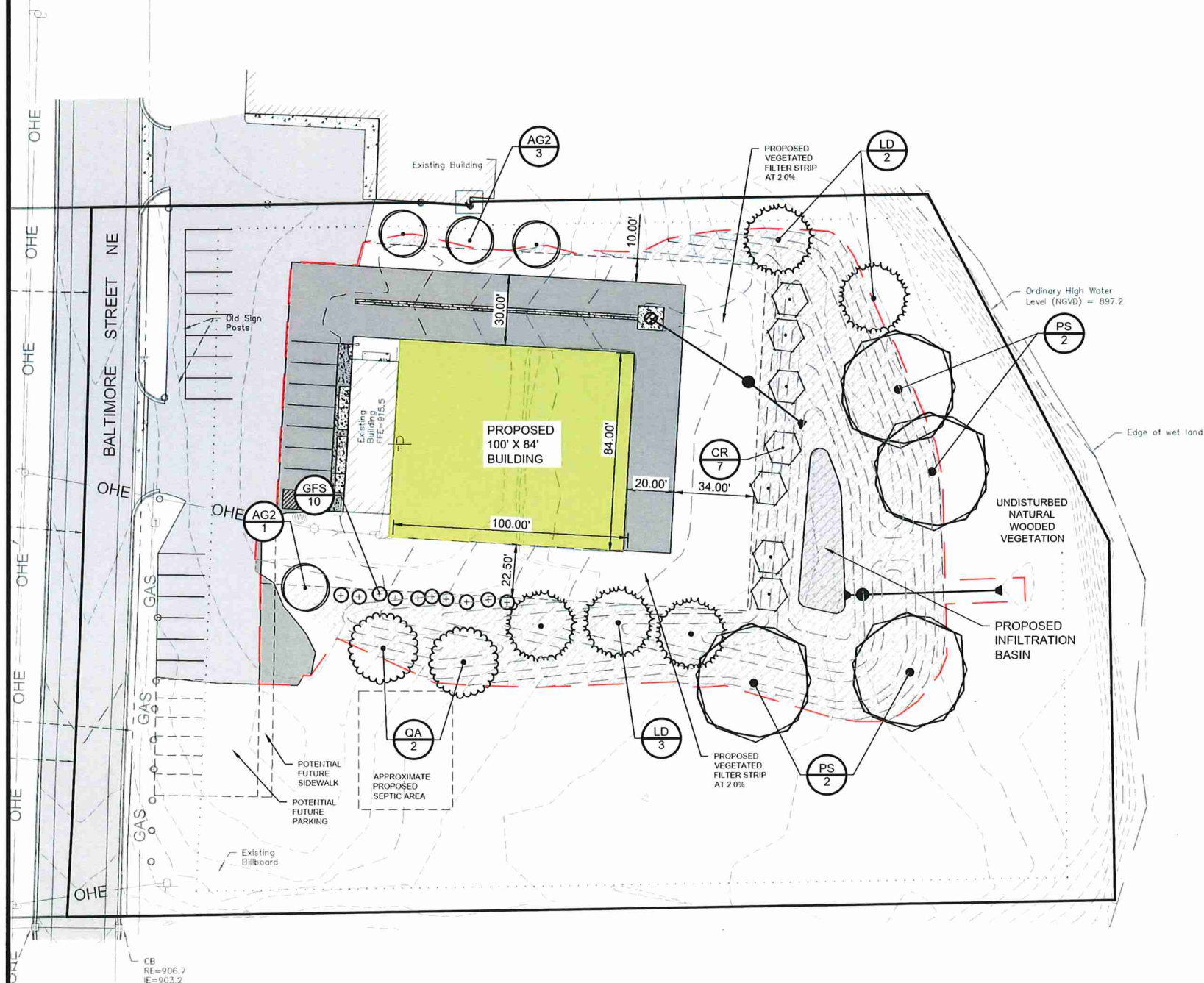
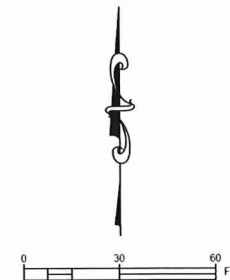

1 TREE SINGLE STAKE PLANTING
 3/8" = 1'-0" FX-PL-FX-TREE-01

PLANTING NOTES

- LANDSCAPE CONTRACTOR SHALL LAY OUT PLANT MATERIAL PER PLAN AND FACE TO GIVE BEST APPEARANCE OR RELATION TO ADJACENT PLANTS, STRUCTURES OR VIEWS. CONTRACTOR TO OBTAIN APPROVAL FROM ARCHITECT PRIOR TO INSTALLATION. PLANT LOCATIONS ARE DIAGRAMMATIC AND MAY BE ADJUSTED IN THE FIELD AT THE ARCHITECT'S REQUEST PRIOR TO INSTALLATION. OBTAIN APPROVAL OF PLANT LAYOUT FROM ARCHITECT PRIOR TO PLANTING.
- MULCH AREAS IDENTIFIED ARE TO RECEIVE 80% 2" - 4" RIVER ROCK AND 20% 1/2" ROCK MULCH OVER 4 OZ. WEED FABRIC, DEWITT "WEED BARRIER" OR APPROVED EQUAL.
- ALL NEWLY PLANTED MATERIAL SHALL BE THOROUGHLY SOAKED WITH WATER WITHIN 3 HOURS OF PLANTING.
- THIRTY DAYS AFTER PLANTING, CONTRACTOR SHALL RE-STAKE AND STRAIGHTEN TREES AS NECESSARY.
- LANDSCAPE CONTRACTOR SHALL THOROUGHLY LOOSEN ANY COMPACTED SUBGRADES PRIOR TO PLACING TOPSOIL, TO A MINIMUM DEPTH OF 10". ROLL SUBGRADES TO PREVENT SETTLING.
- CONTRACTOR WITH RE-USE EXISTING TOPSOIL FROM SITE AND BRING TO FINISH GRADE WITH 4" OF TOPSOIL IN ALL LAWN AREAS, AND 12" OF TOPSOIL IN ALL PLANTING BED NOT ADJACENT TO BUILDING.
- LANDSCAPE CONTRACTOR SHALL REMOVE SOD, CONTAMINATED SOILS, MISCELLANEOUS WASTE MATERIALS FROM AREAS TO BE PLANTED AND SEEDED. CONTRACTOR SHALL LOOSEN COMPACTED SUBSOILS BY TILLING AND IMPORT NEW TOPSOIL AS REQUIRED TO RESTORE GRADES AND MAINTAIN POSITIVE DRAINAGE AWAY FROM THE BUILDING. VERIFY FINAL LIMITS OF AREAS WITH ARCHITECT PRIOR TO COMMENCING OPERATIONS.
- KEEP ALL PLANT MATERIALS MOIST AND SHADED UNTIL PLANTED.
- NO PLANT MATERIAL SUBSTITUTIONS WILL BE ACCEPTED UNLESS APPROVAL IS GRANTED BY THE ARCHITECT TO THE LANDSCAPE CONTRACTOR PRIOR TO THE SUBMISSION OF BID.
- PLANT MATERIALS TO BE INSTALLED PER PLANT DETAILS.
- PLANT MATERIALS SHALL BE FERTILIZED UPON INSTALLATION WITH DRIED BONE MEAL, OR OTHER APPROVED FERTILIZER MIXED IN WITH THE PLANTING SOIL PER THE MANUFACTURER'S INSTRUCTIONS OR MAY BE TREATED FOR SUMMER AND FALL INSTALLATION WITH AN APPLICATION OF GRANULAR 10-0-5 OF 10 OZ. PER 2.0" CALIPER TREE AND 6 OZ. PER SHRUB.
- PLANTING AREAS RECEIVING ANNUALS SHALL RECEIVE A MINIMUM OF 18" DEPTH OF PLANTING SOIL CONSISTING OF 45 PARTS TOPSOIL, 45 PARTS SCREENED COMPOST AND 10 PARTS SAND.
- PERENNIAL AND SHRUB BEDS ARE TO RECEIVE APPLICATION OF PRE-EMERGENT HERBICIDE (PREEN OR APPROVED EQUAL) FOLLOWED BY 4" DEEP MULCH.
- LANDSCAPE CONTRACTOR SHALL WARRANTY NEW PLANT MATERIAL THROUGH TWO CALENDAR YEARS FROM DATE OF SUBSTANTIAL COMPLETION.
- CONTRACTOR SHALL HAVE SUFFICIENT WATERING EQUIPMENT AND/OR FORCES AVAILABLE TO COMPLETELY WATER ALL PLANT MATERIALS ONCE EACH WEEK THROUGH THE WARRANTY PERIOD. WATERING INTERVALS SHALL BE VARIED AND BASED ON PREVAILING MOISTURE AND WEATHER CONDITIONS.
- NO SOIL IS TO BE PLACED ON TOP OF WEED BARRIER FABRIC.

DRAFT - NOT FOR CONSTRUCTION

CAUTION

ALL UNDERGROUND AND OVERHEAD UTILITY LOCATIONS SHOWN ARE APPROXIMATE. THERE MAY BE ADDITIONAL UNDERGROUND AND OVERHEAD UTILITIES NOT SHOWN ON THE PLAN THAT MAY BE REQUIRED TO BE REMOVED. IT IS THE CONTRACTOR'S RESPONSIBILITY TO REQUEST A GOPHER STATE ONE CALL PRIOR TO THE START OF ANY CONSTRUCTION AND COORDINATE ALL WORK WITH THE RESPECTIVE UTILITY COMPANIES.

discharge to public waters.

- B. Development must be planned and conducted in a manner that will minimize the extent of disturbed areas, runoff velocities, erosion potential, and reduce and delay runoff volumes. Disturbed areas must be stabilized and protected as soon as possible and facilities or methods used to retain sediment on the site.
- C. When development density, topographic features, and soil and vegetation conditions are not sufficient to adequately handle stormwater runoff using natural features and vegetation, various types of constructed facilities such as diversions, settling basins, skimming devices, dikes, waterways, and ponds may be used. Preference must be given to designs using surface drainage, vegetation, and infiltration rather than buried pipes and man-made materials and facilities.

12-5.52 Specific Standards:

- A. Impervious surface coverage of lots must not exceed 25 percent of the lot area.
- B. When constructed facilities are used for stormwater management, documentation must be provided by a qualified individual that they are designed and installed consistent with the field office technical guide of the local soil and water conservation districts.
- C. New constructed stormwater outfalls to public waters must provide for filtering or settling of suspended solids and skimming of surface debris before discharge.

12-5.6 Special Provisions for Commercial, Industrial, Public/Semipublic, Agricultural, Forestry and Extractive Uses and Mining of Metallic Minerals and Peat.

12-5.61 Standards for Commercial, Industrial, Public, and Semipublic Uses.

- A. Surface water-oriented commercial uses and industrial, public, or semipublic uses with similar needs to have access to and use of public waters may be located on parcels or lots with frontage on public waters. Those uses with water-oriented needs must meet the following standards:
 - (1) in addition to meeting impervious coverage limits, setbacks, and other zoning standards in this ordinance, the uses must be designed to incorporate topographic and vegetative screening of parking areas and structures;
 - (2) uses that require short-term watercraft mooring for patrons must centralize these facilities and design

them to avoid obstructions of navigation and to be the minimum size necessary to meet the need; and

- (3) uses that depend on patrons arriving by watercraft may use signs and lighting to convey needed information to the public, subject to the following general standards:
 - (a) no advertising signs or supporting facilities for signs may be placed in or upon public waters. Signs conveying information or safety messages may be placed in or on public waters by a public authority or under a permit issued by the county sheriff;
 - (b) signs may be placed, when necessary, within the shore impact zone if they are designed and sized to be the minimum necessary to convey needed information. They must only convey the location and name of the establishment and the general types of goods or services available. The signs must not contain other detailed information such as product brands and prices, must not be located higher than ten feet above the ground, and must not exceed 32 square feet in size. If illuminated by artificial lights, the lights must be shielded or directed to prevent illumination out across public waters; and
 - (c) other outside lighting may be located within the shore impact zone or over public waters if it is used primarily to illuminate potential safety hazards and is shielded or otherwise directed to prevent direct illumination out across public waters. This does not preclude use of navigational lights.

B. Uses without water-oriented needs must be located on lots or parcels without public waters frontage, or, located on lots or parcels with public waters frontage, must either be set back double the normal ordinary high water level setback or be substantially screened from view from the water by vegetation or topography, assuming summer, leaf-on conditions.

12-5.62 Agriculture Use Standards.

- A. General cultivation farming, grazing, nurseries, horticulture, truck farming, sod farming, and wild crop harvesting are permitted uses if steep slopes and shore and bluff impact zones are maintained in permanent vegetation or operated under an approved conservation plan (Resource Management Systems) consistent with the field office technical guides of the local soil and water conservation districts or the United States Soil

NOTICE OF PERMIT APPLICATION STATUS

Project:	Touchdown Tile
Date:	July 25, 2023
Applicant:	Touchdown & Richards Attn: Erik Grams 13837 Lincoln St NE Ham Lake, MN 55304-6947
Permit Application#:	P-23-038
Purpose:	Construction of an 84' x 100' pole barn style building, gravel driveway and parking and associated stormwater treatment features
Location:	15555 Hwy 65 NE, Ham Lake

At their meeting on July 24, 2023, the Board of Managers of the Coon Creek Watershed District approved the above referenced project with 4 conditions and 3 stipulations. **This is NOT a permit.**

Prior to permit issuance, the following conditions must be fulfilled. Please respond to each of these items in writing when resubmitting application materials to the District.

Conditions:

1. Submittal of a performance escrow in the amount of \$2,535.00
2. Provide proof of recording of a fully executed Operations and Maintenance Agreement for the perpetual inspection and maintenance of all proposed stormwater management practices after review and approval by the District.
3. Update construction plans to include a standard detail for the SAFL Baffle that is proposed to be installed in STMH-1
4. After initial grading, completely surround the proposed filtration basins with erosion control measures to prevent the basin from clogging.

After issuance, the permit will include the following stipulations that need to be fulfilled before permit closeout:

Stipulations:

1. Submittal of as-builts for the stormwater management practices and associated structures listed in Tables 2 and 3, including volume, critical elevations and proof of installation for hydrodynamic separators.
2. Completion of (a) post construction infiltration test(s) on the Infiltration Basin by filling the basin to a minimum depth of 6 inches with water and monitoring the time necessary to drain, or multiple double ring infiltration tests to ASTM standards. The Coon Creek Watershed District shall be notified prior to the test to witness the results.
3. If dewatering is required, provide DNR dewatering permit prior to construction. If

a DNR permit is not required, provide well-field location, rates, discharge location, schedule and quantities prior to construction.

Please be advised that **this is NOT a permit**, and that work without a permit is a violation of the terms of the Coon Creek Watershed District Rules. If you have any questions, please call 763-755-0975.

Sincerely,

A handwritten signature in black ink that reads "Erin Edison". The signature is written in a cursive style with a large initial "E".

Erin Edison
Watershed Development Coordinator

cc: File P-23-038
Jordan Wochenske, Stantec
Danielle Tourtillott, Stantec
Tom Collins, Ham Lake

1. Conveyance of Easement and LAWCON Land

At the time of execution hereof, OWNER shall convey the RDU Easement, the TE, and fee title to the LAWCON Land by the deeds attached hereto as Exhibit B and C, respectively. The RDU Easement includes all right of access to or from TH 65, if any.

2. Agreement not to Assess

As a part of the consideration for the promises of Owner as contained herein, City agrees that it will not now or in the future levy any special assessments against the Main Parcel in connection with the current project.

3. Cash Payment for Lawcon Land

City shall pay Owner the sum of \$10,000.00 for the Lawcon Land. The Agreement Not to Assess comprises the consideration for the RDU Easement and the TE.

4. Future Development

In that a substantial amount of buildable land is being taken by City from the Parcels, thereby creating certain situations in which future lot sizes and configurations are adversely affected, it is acknowledged by City that this situation is being created by government action constituting a taking, and the deeds granted herein are in lieu of pending condemnation by City. City acknowledges that the Property is entitled to treatment under Article 9-150.5(d) of the Ham Lake City Code, meaning Owner is entitled to reasonable variances to the lot size, frontage and setback requirements of the City's current Code, and that the right to develop under the current code is to be deemed "Grandfathered" by virtue of the substantial reliance Owner is placing on current code requirements in conveying the various property rights.

5. Tree Damage

City represents that no damage will occur to three trees now in the TE during construction.

6. Surveyor's Drawing

Within 15 days, City will furnish a surveyor's drawing showing the locations and legal descriptions of the easements and the LAWCON land areas.

7. Grading

During construction, City will direct its contractor to fill a depression that is located in the TE area, and grade the fill to match the surrounding elevation. The contractor may need to

Resolution 23-

WHEREAS, Touchdown Tile, et al, are the owners of the following parcel:

15555 Baltimore Avenue NE, Ham Lake, MN 55304
PIN: 20-32-23-12-0025

And,

WHEREAS, the City's service road project between 153rd Avenue NE and 157th Avenue NE included the acquisition of numerous easements and access control rights, some of which directly or indirectly touch upon the parcel, but which nevertheless directly affect the parcel by limiting the amount of space that has been traditionally used by the owner for parking and driveways, and

WHEREAS, Ham Lake City Code Article 9-150.5 (d) specifically authorizes the City Council to grant variances to any City Code section where governmental action has affected the utility of any parcel of land,

NOW THEREFORE, BE IT RESOLVED BY THE CITY COUNCIL OF THE CITY OF HAM LAKE, ANOKA COUNTY, MINNESOTA, AS FOLLOWS:

Findings of Fact

1. The City of Ham Lake acquired right-of-way from said parcel;
2. The City of Ham Lake in the purchase agreement identified items that would be eligible for variances, including sign setbacks;
3. Allowing a variance to the ten-foot setback from the west lot line will help to alleviate the spatial problem created by the governmental action and meets the intent of Article 9-150.5 in terms of qualified situations.

Accordingly, a variance is hereby granted to the owner and the parcel to locate signs within the 10-foot setback line from the west property line.

Accordingly, a variance is hereby granted to the owner and the parcel to locate parking within the 10-foot setback line from the west property line.

**ADOPTED BY A _____ VOTE OF THE HAM LAKE CITY COUNCIL THIS 21st
DAY OF AUGUST, 2023.**

CITY SEAL

Brian Kirkham, Mayor

Attest:

Denise Webster, Administrator

Excerpt from Article 9 of the Ham Lake City Code

...

9-220 Mercantile Districts The land uses described in Article 9-220 are intended to be applicable to developments which utilize subsurface sewage treatment systems (SSTS), and to developments which use approved combined sewage treatment systems. All building permits and Certificates of Occupancy in the Mercantile Districts shall require the review and approval of the City Council, after review and recommendation by the Planning Commission, excepting building permits and/or certificates of occupancy being issued for an alteration to an existing structure under circumstances in which the land use will be unchanged, and in which the alteration will not materially affect parking requirements, stormwater runoff, traffic, sewage treatment needs or aesthetics.

9-220.1 Standards Common to All Mercantile Districts

The following standards shall apply to all of the mercantile districts as listed in Article 9-220.

- a) **Paving** All parking lots, drives and surfaces upon which the general public and employees shall have access shall be paved according to specifications to be established by the city's engineer;
- b) **Drainage** Surface water drainage and ponding needs shall be implemented in the manner directed by the city's engineer;
- c) **Landscaping** Landscaping shall be implemented in the manner provided in Article 11-1800;
- d) **Setbacks for Paved Areas** There shall be a ten-foot setback between any lot line and the back of curb of any parking lot or driveway, and a six-foot setback between the back of curb of any parking lot and any building;
- e) **Buffering** When any mercantile land use is located adjacent to a residential area, it shall be screened by opaque fencing, vegetation, or both;
- f) **Refuse Containers** Refuse containers shall be stored in locations which are completely screened from outside view; hazardous materials shall be stored and disposed of in the manner provided by law;
- g) **Parking Lots and Lighting** Off-street parking shall be provided for the general public and employees. The *Zoning Officer* shall maintain a schedule of parking requirements, to be ratified from time to time by resolution of the City Council, to serve as the general guideline for the establishment of parking requirements, subject to modification by the City Council where merited. Security lighting shall be permitted, and may be required on review of site plans, but shall be directed away from adjacent properties. No light or

combination of lights that cast light upon a Residential Land Use shall exceed 4-foot candle meter reading as measured at the residential property line. All measurements shall be made after dark at the property line or edge of roadway.

- h) Off-Street Loading** All deliveries and bulk pickups of merchandise, inventory and supplies shall be made to loading facilities preferably located in the rear of the building, which loading facilities shall be sufficient to enable the prompt and safe transfer of goods.
- i) Signage** All signage shall conform to the provisions of Article 11-300.
- j) Special Considerations** Notwithstanding the limitations as to building styles, construction types and exterior treatments, the City Council, after Planning Commission review, may depart from strict adherence to the standards found in Article 9-220, where special conditions merit such departure, and where certain standards are met. Such special conditions and standards may include, without limitation, the following items.

 - i)** The departure is not being requested for purely economic reasons;
 - ii)** The nature of the business is such that it requires a specific type of building construction in order to improve the business function, such as requirements for sunlight, specialty equipment, interior lighting or the like;
 - iii)** The business is a permitted or conditional use in the zoning district;
 - iv)** The applicant proposes the usage of special aesthetic treatments which provide a superior exterior view, such as landscaping, vegetation screening, berming, or the like;
 - v)** The property contains unusual topography, mature vegetation or other features which can be preserved or enhanced to produce an overall superior appearance;
 - vi)** The property contains unusual accessibility problems to or from adjacent roadways;
 - vii)** The applicant offers to implement more stringent design limitations in certain site plan features than would normally be required, in exchange for being

permitted less stringent design limitations in other site plan features.

- k) **Outside Storage** Outside storage and activities for areas zoned CD-3, CD-4, Industrial Park (I-P) and Light Industrial (I-1) shall be as specifically detailed in the Code Sections dealing with those land uses (Articles 9-220.4 through 9-220.7). For areas zoned CD-1 and CD-2, the following provisions shall apply to outside storage, excepting Fireworks sales and storage, which are governed by the provisions of Article 9-330.6. **Unless specifically permitted by this Article 220.1(k), no Outside Storage shall be allowed in any area zoned CD-1 or CD-2.**

1) Definitions

- aa) **Outside Storage** – personal property (not fixtures) that are located within the Approved Property Lines of any parcel bearing a CD zoning classification, but which are found outside of an enclosed, roofed building (including temporary structures). Outside Storage does not include Refuse Containers, customer vehicles, employee vehicles parked while the employee is on duty, delivery vehicles while in the process of delivery or pickup, construction materials or vehicles being used in an active construction project on the parcel, legal signs or banners, or legal temporary structures. Except where specifically excepted, Outside Storage does include inventory of the business occupying the parcel.
- bb) **Inventory** - goods, except Vehicle Inventory, that are offered for sale in the ordinary course of business of any business occupying the parcel. For auto repair shops, inventory shall also be deemed to mean passenger vehicles or pickup trucks awaiting repair services.
- cc) **Vehicle Inventory** – Automobiles, Trucks, Trailers, Manufactured Homes, Recreational Vehicles, Campers, Camper Tops, Truck Toppers, Boats or other wheeled conveyances that are offered for retail sale at a legal business location whose primary business is the retail sale of one or more of the above items. Rental equipment that may be offered for sale is not Vehicle Inventory. Vehicle Inventory that bears obvious signs that the vehicle is not presently capable of being legally operated or conveyed on a public road is not Vehicle Inventory, including, but not limited to vehicles lacking wheels or inflated tires, operable drive train components, broken windows or lights, required current vehicle registration, missing body parts, such as fenders, doors, hood lids, trunk lids, bumpers, lights or trim.

- dd) **Aesthetically Screened Outside Storage** - Inventory or Vehicle Inventory behind an opaque barrier constructed of masonry or brick, attached to and matching or complementary to the main building, and of sufficient height and design so as to give the appearance that the barrier is a part of the main building. No object shall be stored inside of such a barrier if the object protrudes above the height of the barrier. Any gates through the barrier shall be opaque and of aesthetic design.
- ee) **Limited Outdoor Displays** - Temporary displays of merchandise which are normally sold or displayed from within an enclosed retail store location, but which are temporarily placed not more than ten feet from an outside wall of the main retail sales building during business hours, and then returned to inside storage during non-business hours.”
- ff) **Improvement Stores** – Businesses that have as their primary source of revenue the retail sale of plants, seeds, landscaping supplies, produce, or yard statuary.
- gg) **24-Hour Convenience Stores** – Businesses that sell gasoline at retail, and, from the same store location, also sell groceries, auto supplies, sundries, over-the-counter medications and personal products, sundries and other items for human consumption, and which remain open for business at all times of every day.
- hh) **Approved Property Lines** – Are the outside perimeter of the real estate parcel or parcels which were shown on the site plan used for the initial municipal approval of a certificate of occupancy or conditional use permit for a particular operation.
- ii) **Pool Stores** – retail stores that engage in the retail sales of above ground or below ground recreational swimming pools that contain electric filtration devices providing water circulation and filtration in the pool, and under conditions where an inventory of above ground or in ground swimming pools is maintained, connected by water and electricity to a source originating in a permanent retail building located on the same parcel. A Pool Store shall not be considered a retail store for the purposes of determining permitted uses under Article 9-220.2 (b) or 9-220.3(b).
- jj) **Screened Outside Storage** – is Inventory or Vehicle Inventory behind an opaque barrier constructed of wood, metal, plastic, masonry, brick or earthen berm, or which is behind an opaque barrier composed of existing buildings or other structures on the property, or which is behind a semi-opaque barrier of vegetation that substantially conceals the storage from outside view.

2) Permitted Outside Storage

- aa)** Vehicle Inventory is permitted Outside Storage on any CD-1 or CD-2 parcel in connection with a business that is legally permitted to sell Vehicle Inventory. If specifically permitted by the conditions of any Conditional Use Permit or Temporary Conditional Use Permit for any such parcel, vehicles that do not meet the definition of Vehicle Inventory may also be permitted Outside Storage.
- bb)** Aesthetically Screened Outside Storage is permitted outside storage if used as a condition of approval of any site plan, Conditional Use Permit or Temporary Conditional Use Permit on any CD-1 or CD-2 parcel in connection with the new construction of a main commercial building on the parcel.
- cc)** Limited Outdoor Displays are permitted Outside Storage in both the CD-1 and CD-2 districts. If the business is a 24-Hour Convenience Store, the Limited Outdoor Display need not be moved indoors, but the business shall at all times maintain a clear pedestrian path on sidewalks that is at least 36 inches in width.
- dd)** Inventory is permitted Outside Storage for Improvement Stores and Manufactured/Prefabricated Structure Sales but must be separately identified on the initial site plan submitted with the initial request for certificate of occupancy or conditional use permit, and must be stored only in conformance with that site plan. Bins or containers housing the Inventory shall also be permitted Outside Storage for Improvement Stores and Manufactured/Prefabricated Structure Sales as shall be other items necessarily incident to the storage, maintenance or protection of the Inventory.
- ee)** No Outside Storage shall be permitted for any business unless the storage is within the Approved Property Lines.
- ff)** Pool Stores may display above ground or below ground swimming pools as Permitted Outside Storage only on property under conditional use permit, subject to conditions to be established by the City Council, which must include, at a minimum, the following:
 - 1)** Pool water must be maintained in a sanitary condition;
 - 2)** Below ground pools must be surrounded by code-compliant fencing;
 - 3)** Above ground pools must be constructed in a code-compliant method relative to either fencing or sufficient elevation to prevent accidental entry into the pool;
 - 4)** Adequate security fencing around the storage display area must be installed to discourage after-hours entry into the pool storage area;

- 5) Reasonable screening from outside view shall be installed;
- 6) All sources of water and electricity shall be connected to the pools in a code-compliant manner;
- 7) Only pools that are intended for use with circulating filters shall be permitted outside; no "kiddy pools", wading pools or inflatable pools shall be permitted to be displayed outside.
- 8) Winter storage of outside pools shall be done in a manner that covers the pool surface and prevents the accidental entry into the pool;
- gg) Screened Outside Storage is permitted outside storage if used as a condition of approval of any site plan, Conditional Use Permit or Temporary Conditional Use Permit on any CD-1 or CD-2 parcel involving pre-existing main buildings or structures that:
 - 1) Historically utilized outside storage in connection with business operating on the property, and which uses were never abandoned;
 - 2) Do not involve replacement or major remodeling of the existing structures, but utilizes the existing structures for the business to be operated;

Approval of Screened Outside Storage is discretionary with the City Council.

- hh) **Revocation** All permits and certificates of occupancy issued in the mercantile districts are subject to revocation under the provisions of Article 9-240.

- 3) **Office/Warehouses** Office/Warehouse is a term given to a structure that is designed to have office space in front, behind which is situated an open bay or bays, with the office and bay space to be occupied by a single business. The office space and the bay space may also include area for retail sales. The bay space may also be used for manufacturing, other industrial activity, or warehousing. Building Permits may be issued for Office/Warehouses in any Mercantile District as found in Article 9-220. However, specific uses within each Office/Warehouse are subject to the Permitted Use, Conditional Use and Temporary Conditional Use restrictions for the given zoning district in which the Office/Warehouse is constructed. The issuance of a building permit for an Office/Warehouse does not confer upon the property owner the right to use any portion of the structure in a manner inconsistent with the use restrictions for the zoning district in which the structure is located. All new tenants or occupants of any Office/Warehouse must observe the same conditions for site plan or other approval, as would any other occupant. Further, if the zoning district in which the Office/Warehouse is to

be constructed contains restrictions on building materials or design, those restrictions must be followed. No outside storage unless permitted by Conditional Use Permit, Temporary Conditional Use Permit, or by the given zoning district in which the Office/Warehouse is constructed.

9-220.2 Commercial Development I (CD-1)

The CD-1 zone is intended to apply to certain commercial uses on lands abutting the city's only major thoroughfare, Trunk Highway 65. In that these lands have high visibility to the traveling public, it is considered important to the preservation of land values in general, as well as important to the continuing ability of the city to generate the establishment of quality commercial development and the concomitant tax and employment base, that structures in the CD-1 zones observe specific construction and aesthetic standards, which are listed below. No usage shall be permitted in the CD-1 zone which does not observe the standards found in Article 9-220.2 (a) below.

a) Standards for Site and Building Construction

- i) Except for structures housing public utility feature, no metal or pole-type building shall be permitted;
- ii) Exterior wall surfaces shall be of brick, decorative masonry, stone, precast panel, architectural concrete, glass, stucco, architectural metal panel with hidden fasteners; or wood framed with horizontal lap siding;
- iii) No galvanized surfaces shall be permitted, either on roofs or siding;
- iv) All roofs shall be colored and shall incorporate a minimum 18-inch soffit on the eave edge of the roof;
- v) All roofs shall have a minimum 12-inch overhang on the gable ends;
- vi) All roofs have a minimum 6-inch fascia;
- vii) Standing metal seam roofing shall be permitted (minimum 24-gauge, non-galvanized);

b) Permitted Uses (Including uses that are ancillary to the main use)

- Clubs and Lodges
- Medical Facilities
 - Assisted Living Facilities
 - Chiropractic
 - Clinics of all medical disciplines
 - Dental
 - Diagnostic Facilities
 - Hospitals
 - Laboratories

- Nursing Homes
- Residential Treatment Centers
- Treatment Rooms and Centers
- Veterinary Clinics
- Hotels, Motels and Lodging Houses under Article 11-1100
- Light Manufacturing, defined as follows: The fabrication or processing of goods for sale to retailers, wholesalers, other manufacturers or at retail that takes place entirely within an enclosed building and that meets the following criteria:
 - a) The business does not generate any noise, odor or vibration detectable from adjoining properties, other than that which occurs in the normal course of business during shipping and receiving activities;
 - b) There is no outside storage of any item except Aesthetically Screened Outside Storage as defined in Article 9-220(k)(1)(dd) of this Code.
 - c) No outside cranes or booms are located on the site;
 - d) Retail sales of the business products can occur on the premises if the commodities are the commodities manufactured on site.
- Offices and Office Buildings
- Office Warehouses
- Park and Ride Lots
- Post Offices
- Public Utilities (metal or pole type construction allowed)
- Recreational Facilities (indoor unless noted)
 - Batting Cages
 - Billiard Parlors
 - Bowling Alleys
 - Dance/Gymnastic Studios
 - Health Clubs
 - Martial Arts Studios
 - Miniature Golf Courses (outdoor)
 - Paintball or Laser Tag Facilities
 - Parks (outdoor/publicly owned)
 - Roller Skating Facilities
 - Shooting Range
 - Skateboard Facilities
 - Virtual Golf Facilities
- Restaurants, including liquor service
- Retail Facilities - engaged in the sale of goods (Excluding Motor Vehicle/ Boat/RV/Camper Sales), from freestanding one-store locations, shopping centers, strip malls or enclosed malls, including, but not limited to:
 - Antique Stores
 - Appliance Stores

- Automobile Parts Stores (new parts only)
- Bakeries
- Bicycle Stores
- "Big Box" Stores (subject to Article 9-400)
- Book Stores
- Butcher Shops/Meat Markets
- Camera Stores
- Candy Stores
- Carpet Stores
- Clothing Stores
- Coin Stores
- Convenience Stores
- Cosmetic Stores
- Discount Stores
- E-Cig Stores
- Electrical, HVAC and Plumbing Equipment Stores
- Electronics Stores
- Fireworks (under Article 9-330.6)
- Floral Stores
- Furniture Stores
- Gift Shop
- Grocery Stores
- Hardware Stores
- Health Stores
- Hobby/Game Stores
- Housewares Stores
- Improvement Stores (Lawn & Garden) as defined in Article 9-220.1 (k)(1)(ff)
- Jewelry Stores
- Liquor Stores
- Luggage Stores
- Music Stores
- Office Supply Stores
- Optical Supply Stores
- Paint/Wallpaper Stores
- Pet Stores
- Petroleum product sales (excluding vehicle repair)
- Pharmacies
- Shoe Stores
- Sporting Goods Stores
- Souvenir Stores
- Thrift Stores
- Tobacco Stores
- Video Stores
- Schools and Colleges
- Service Businesses with no outside storage or displays

- Service Businesses
 - Appliance Repair Shops
 - Barber Shops
 - Beauty Shops
 - Car Washes
 - Day Cares (licensed)
 - Dry Cleaners
 - Electronics Repair Shops
 - Financial Institutions
 - Funeral Homes
 - Government Buildings
 - Insurance Agencies
 - Law Offices
 - Locksmiths
 - Manicure/Pedicure/Nail Care shops
 - Pet Grooming Shops
 - Photography Studios
 - Print Shops
 - Shoe Repair Shops
 - Specialty Retail Shops
 - Tailor Shops
 - Tanning Facilities
 - Travel Agencies
- Small Engine Sales and Repair
 - Air Compressors
 - Chain Saws
 - Garden Tractors
 - Lawn Mowers
 - Leaf Blowers
 - Other Motorized Gardening Equipment
 - Power Rakes
 - Power Washers
 - Rototillers
 - Shop Vacs
 - Snowblowers
 - Woodchippers
 - Wood-splitters
- Theatres
- Therapeutic Massage where the business meets the following criteria:
 - a) *Therapeutic Massage* means the practice of administering physical therapy through the massaging, rubbing, kneading or other manipulations of the body, administered solely for therapeutic purposes, but not intended to result in the sexual gratification of the recipient.
 - b) No person shall engage in *Therapeutic Massage* who is not a *Massage Therapist* (defined as a person who maintains

certification with the National Certification Board for Therapeutic Massage & Bodywork (NCBTMB), has passed the MBLEx examination given by the Federation of State Massage Therapy Boards, is a member in good standing in the American Massage Therapy Association (AMTA), or is a member in good standing in the Associated Bodywork and Massage Professionals (ABMP);

- c) Hours of operation shall be limited to 8:00 am to 10:00 pm;
- d) The business shall at all times maintain a complete listing of all persons engaged as *Massage Therapists* and shall on request of City staff furnish evidence that each such person meets the qualifications to be a *Massage Therapist*.
- Worship Centers and ancillary features owned by the entity that owns the Worship Center, including classrooms, recreational features, residences for staff, offices and kitchen/dining.

Excerpt from Article 11 of the Ham Lake City Code

...

11-1800 LANDSCAPING IN COMMERCIAL ZONED AREAS

In all areas of the City zoned CD-1, CD-2, CD-3 or CD-4, the following conditions shall apply to landscaping and ground cover.

11-1810 Landscape Plan Required No building permit shall be issued for construction on a vacant lot, nor for any addition to an existing building involving the addition of 500 square feet or more of additional building space, unless the applicant shall have first submitted and obtained approval of the City Council, after review by the Planning Commission, of a landscaping plan meeting the requirements of this code.

11-1820 Installation Required No certificate of occupancy shall be issued for any construction which required a landscaping plan unless the applicant has installed all of the elements of the landscaping plan, or unless the applicant has posted security acceptable to the City to guarantee timely installation of all landscaping.

11-1830 Time for Submission The landscaping plan shall be submitted, whenever possible, at the time of site plan approval. If the landscaping plan is not submitted at the time of site plan approval, it must be separately reviewed by the Planning Commission and approved by the City Council prior to the issuance of any building permits.

11-1840 Contents and Specifications

The landscaping plan shall be a quality document prepared at a scale of one-inch equals thirty feet, showing all relevant dimensions. Fifteen copies of the plan shall be submitted by the applicant. The following data shall be displayed on the plan, legibly labeled:

- A. Perimeter of all buildings, signs or other structures;
- B. Parking lots and walkways, identifying pavement material;
- C. Areas of decorative rock, identifying type of rock;
- D. Areas of lawn;
- E. Other areas where other than natural wooded vegetation is to be used as ground cover, identifying the ground cover to be used;
- F. Locations, trunk size, height and species of all trees to be planted;
- G. Locations where existing natural wooded vegetation will remain undisturbed;
- H. All other landscaping features to be used.

11-1850 MINIMUM LANDSCAPING REQUIREMENTS

11-1851 Paved Surfaces All surfaces upon which motor vehicles will be parked or driven, and all areas in which pedestrians will be walking from point to point shall be surfaced with asphalt or concrete, to specifications established by the City's engineer.

11-1852 Ground Cover On any side of a lot which abuts a public road, the area from the road right-of-way to the nearest building side shall be entirely covered with ground cover consisting of pavement, decorative rock bordered with edging, lawn grass intended for regular mowing, mulch, bark, wood chips or other commonly used landscaping ground cover. Shingles, aggregate and clay mixtures such as Class V material, recycled concrete or asphalt, and other non-conventional ground covers shall not be permitted. Loose ground cover shall be installed to a depth of at least three inches. Any area which is covered by landscaping ground cover (not lawn or pavement) shall also include one decorative shrub for each ten square feet of ground cover.

Side yards and rear yards which do not contain existing natural wooded vegetation shall either be covered with ground cover in the manner stated above for front yards, or shall be planted so as to encourage the emergence of natural wooded vegetation, through the planting of tree species expected to reach a height of at least twenty five feet. Areas so prepared shall not be required to have mown lawn areas, but may be allowed to return to a natural state.

11-1853 Tree Plantings Trees which are planted outside of areas intended to return to a natural wooded state shall be of a variety indigenous to the local climate. Deciduous trees shall, when planted, have a trunk size of at least one and one half inches at a height of four feet from ground level. Conifers shall have a height of at least five feet. Tree locations are subject to review and approval of the City in the landscaping plan review process, and while no specific number of trees are required, the following general principles shall be observed;

- A.** Where property lines are adjacent to residential areas, a planting screen of conifers shall be required, of sufficient size and proximity to provide an intermingled screen within five years;
- B.** Decorative trees shall be planted along the right of way lines of adjacent public roadways;
- B.** The use of conifers shall be encouraged and preferred.
- C.** Whenever possible, an attempt will be made to preserve stands of existing vegetation, particularly treed or wooded areas.

11-1860 Case by Case Evaluation

Recognizing that the City contains a wide variety of commercial land, the landscape approval process shall be on a case by case basis. Where wetlands are present, or where large distances separate a commercial lot from adjacent lands, for example, strict adherence to screening requirements may be unnecessary. Likewise, strict adherence to the remaining provisions of Article 11-1800 may be unnecessary where size, spatial relationships, topography or other physical features render a given landscaping plan aesthetically acceptable, and departures from the strict observance of the elements of Article 11-1800 shall not be considered variances requiring a showing of physical hardship. Conversely, an applicant shall be expected to meet the general spirit of this article in establishing an aesthetically pleasing landscaping plan.